

# Clamping elements

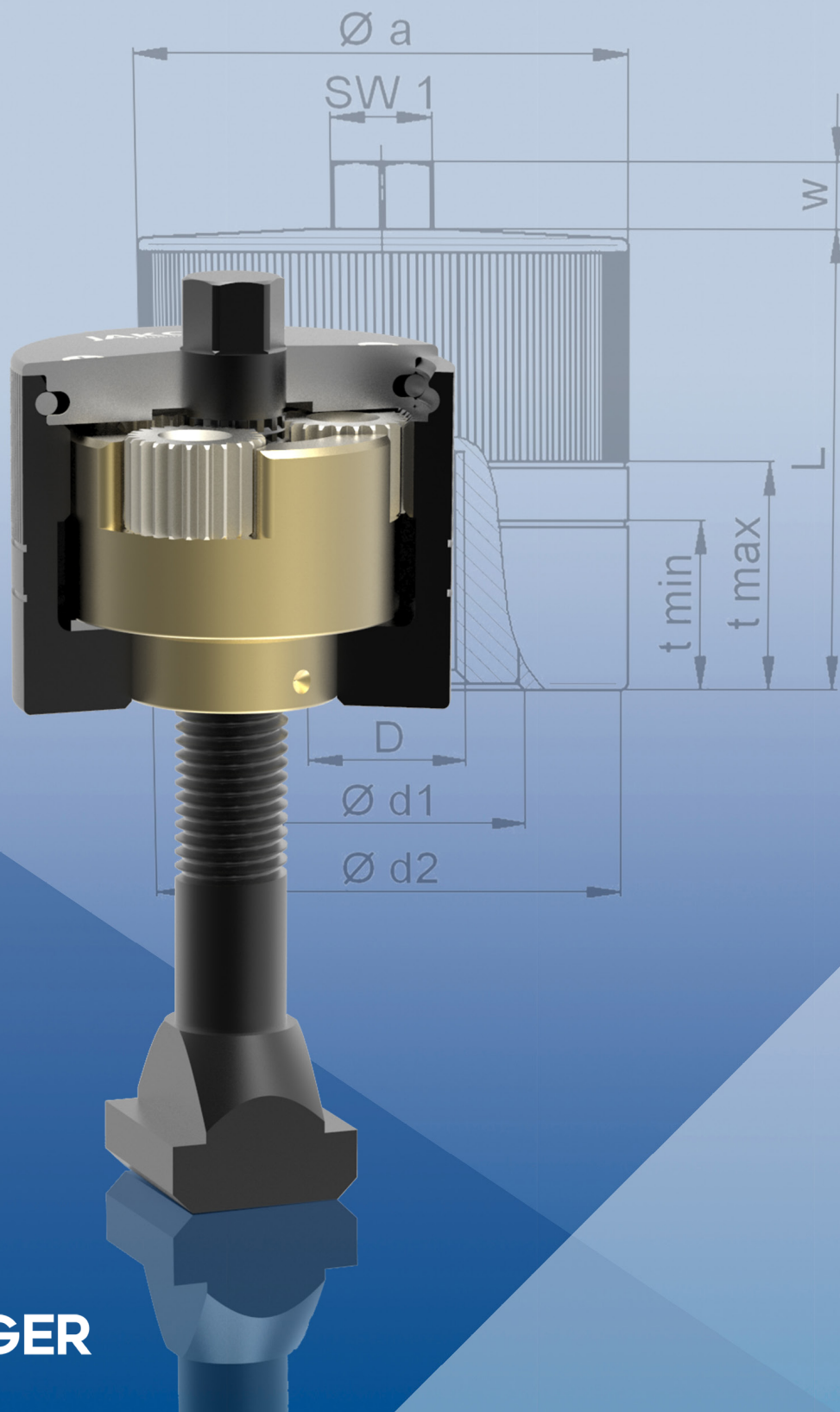

## The company JAKOB

JAKOB Antriebstechnik GmbH is a leading manufacturer of servo couplings, safety couplings and mechanical clamping elements internationally.

For almost 50 years JAKOB has been developing and producing various types of torsionally stiff metal bellows couplings and safety couplings for the servo drive industry. Throughout our history we have earned ourselves the reputation of being a reliable and competent partner in the motion control industry.

JAKOB is a market leader in the area of mechanical tool and component clamping with its innovative and unique

clamping technology. The JAKOB wedge clamping technology combines high clamping forces with low actuation torques and maximum operating safety.

The goal of our clamping element catalog is to provide a general overview of our standard product range. More detailed information can be obtained at our homepage [www.jakobantriebstechnik.de](http://www.jakobantriebstechnik.de).

Highly trained engineers and technicians at our facility in Kleinwallstadt are always ready with a solution to best meet your requirements.



3D-models in STEP format are available for download at the corresponding site of our homepage. For special dimensions or different drawing types please contact JAKOB.





**Telephone +49(0)6022 2208-0**  
**[www.jakobantriebstechnik.de](http://www.jakobantriebstechnik.de), [info@jakobantriebstechnik.de](mailto:info@jakobantriebstechnik.de)**

Technical changes reserved.  
Most recent data sheets available on the internet.

Please feel free to contact us about our extensive product range of servo and safety couplings, as well as protective solutions for the motor-spindles of machine tools.



## Directory Clamping Elements I Overview

|  | page  |
|--|-------|
| <p><b>Mechanical Power Clamping Nut</b></p>  <p><b>MCA/</b> // with blind hole thread // thread protected<br/> <b>MCG</b> // centered operation // compact design<br/> // optionally with star- or T-knob (MCA) // with threaded pin (MCG)<br/> <b>MCA-DB</b> // with integrated torque limiter<br/> <b>MDA</b> // with through hole thread // unlimited clamping stroke<br/> <b>MDR</b> // for variable clamping edges</p>   | 1-8   |
| <p><b>Mechanical Power Clamping Screws</b></p>  <p><b>SC</b> // wedge mechanism as force amplifier<br/> // high clamping forces at low actuation torques<br/> // maximum operating safety – self-locking mechanism<br/> // simple, manual operation</p>   | 10-12 |
| <p><b>Mechanical and Hydromechanical Power Clamping Screws</b></p>  <p><b>MSP/</b> // high operating travel // maximum reliability<br/> <b>MSPD</b> // simple handling and mounting<br/> // for face plates and jaw boxes<br/> // mechanical force amplifier for external clamping direction<br/> // double acting version for internal and external clamping directions<br/> <b>HSP</b> // hydromechanical force amplifying for external clamping direction<br/> // nominal clamping forces up to 750 kN // low actuation torques</p> | 13-17 |
| <p><b>Force Monitoring</b></p>  <p><b>HMD</b> // increase in operational safety<br/> // confirmation of proper clamping state</p>   | 18-19 |
| <p><b>Hydromechanical Spring Clamping Systems</b></p>  <p><b>ZSF</b> // spring pressure cylinder (pull)<br/> <b>ZDF</b> // spring pressure cylinder (push)<br/> // mechanical clamping // hydraulically released<br/> // maximum operating safety // leak-proof and robust<br/> // nominal clamping forces up to 350 kN</p>   | 20-25 |

## Clamping Technology I General

### Definition:

Clamping tasks in manufacturing technology are versatile and numerous; the elements and systems supplied will gain ever greater importance in the future due to the requirements placed on short setup and manufacturing times. When selecting suitable clamping equipment, reliability, cost effectiveness, user friendliness and technical details are the most important factors. Additional aspects are increasing quality, flexibility and ergonomics demands in the work area. Mechanical clamping elements from JAKOB with multiple patented power amplification systems and hydromechanical clamping systems meet the high requirements of the user.

At the same time, they provide a genuine alternative to simple, mechanical clamping equipment (steel ties, brackets, etc.) along with semi- and fully-automatic clamping elements, which usually have highly elaborate energy supplies and control systems. With their low installation costs, the minimal operating and maintenance expenditures and the moderate procurement price, JAKOB clamping elements are often the most cost effective solution. Whether as original equipment or as retrofit elements, JAKOB clamping elements always hold tools and workpieces in position securely.

### Characteristics:

- ✓ highest clamping forces ✓ low actuation torques ✓ large operation path
- ✓ high operational safety ✓ clamping force control
- ✓ easy installation ✓ economical clamping technology
- ✓ more humane workplace ✓ reduced risk of accidents
- ✓ simple & manual operation or automatic mode
- ✓ versatile application through compact and flexible design

### Clamping elements with power amplification:

This group of clamping elements includes mechanical power clamping screws and power clamping nuts. They are designed for manual operation with simple handling but at the same time allow very high clamping forces. The manual actuation torque is also used for clamping force monitoring. Various clamping mechanisms such as key systems, planet gears or pressure distributors are used for power amplification. The sturdy design, the self-locking feature and a very high overload capacity ensure maximum reliability and long time life in these clamping

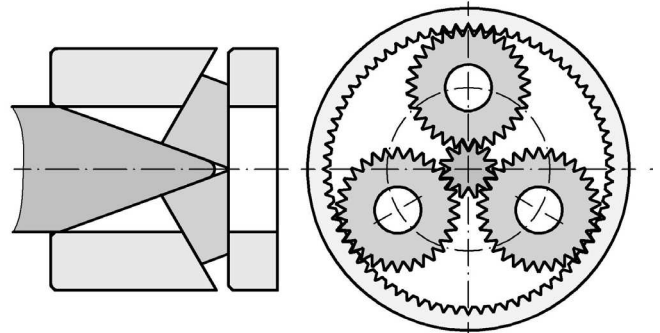

### Hydromechanical spring tension system

The hydromechanical spring tension system is characterized especially by high reliability and low operating costs. The clamping force is actuated leakproof by a disk spring packet while the hydraulic pressure is only required for the release process. This results in highly compact, sturdy and reliable clamping elements, such as spring clamping cylinders, spring pressure cylinders, and spring clamping nuts.

mechanical  
Power Clamping Nuts



## Mechanical Power Clamping Nut I MCA/MDA/MDR/MCG

- ✓ maximum clamping forces through force amplification
- ✓ simple & manual operation – low actuation torques
- ✓ high operational safety through self-locking mechanism
- ✓ corrosion - resistant, robust, up to 400°C

The salient design feature of the MCA, MCG, MDA and MDR series is an integral transmission gear for the amplification of the manual actuation torque. With this, the user has a sturdy and flexible clamping element which allows for high clamping forces with simple manual operation and maximum operational safety.

The MCA and MCG series are designed with blind hole thread or threaded bolt and a centrally arranged operating hexagon, the MDA and MDR series with a through hole thread and sidewise respectively radial arranged hexagon design. The power clamping nut can be used for various clamping tasks throughout the machine tool industry, particularly for clamping in presses and punches.

### Available options:

- ✓ high temperature version up to  $T = 400^{\circ}\text{C}$
- ✓ corrosion-resistant version for demanding ambient conditions
- ✓ with additional latch mechanism for automatic switch over to power clamping mode for fast feeding or in a lowered layout (standard in types MCA 60, MCA-T, MCA-S, MDA, MDR)
- ✓ lubrication with food grease for the food industry, laboratory area, etc.
- ✓ torque wrench or operation tools upon request

### Function and handling:

After manually tightening the clamping nut up to the surface, the drive pinion is activated through a right-hand turn of the actuation hexagon SW 1 or SW 2. The gearbox ratio tightens the torque with a high multiplier and the rotation of the threaded nut produces the clamping stroke of the threaded tension bolt. The clamping force is built up depending on the actuation torque.

Self-locking is guaranteed in every clamping position. To reliably ensure the necessary clamping force on one hand and to protect the clamping mechanism from damage caused by excessive actuation torques on the other, the use of a torque wrench is recommended.

In certain circumstances, clamping with the help of normal box spanners, angle wrenches and ratchet spanners may be acceptable while the use of impact wrenches is not. The operating direction “clamping / releasing” as well as the respective, specific operating torque is indicated by means of an engraving on the top of the clamping nut. Make sure that the threaded-down stud bolts are fixed; i.e. that they cannot be turned.

The power clamping nuts are maintenance-free under normal operating conditions. The tempered steel housing and threaded nut are corrosion-resis-

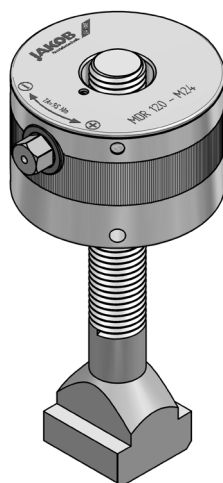

**MDR**

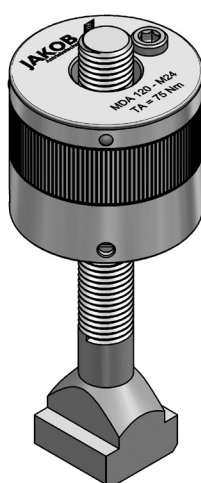

**MDA**

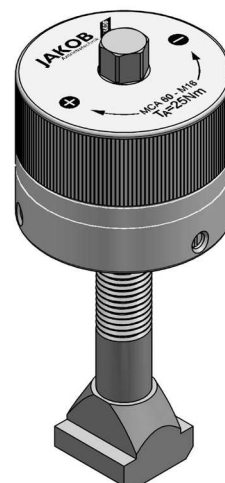

**MCA**

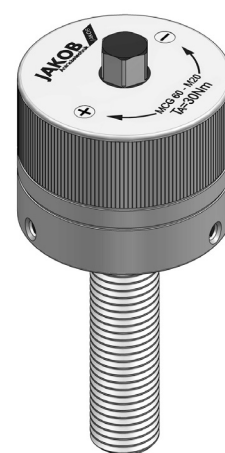

**MCG**

# Mechanical Power Clamping Nut I Series MCA-S/MCA-T

/// simple & manual operation with handle // fast infeed motion due to automatic changeover

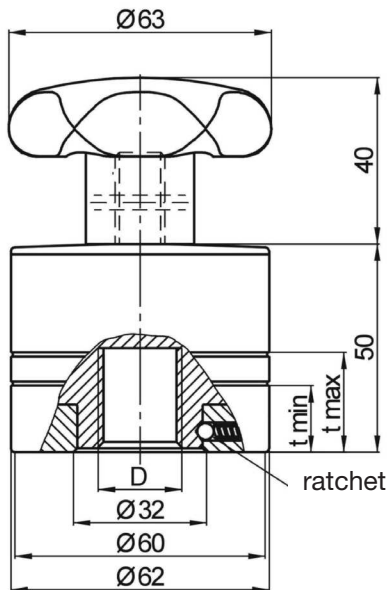

**clamping nut MCA-S  
with star handle**

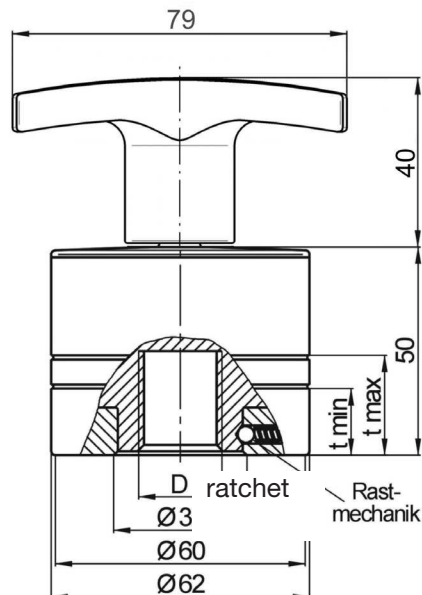

**clamping nut MCA-T  
with T-handle**

material:  
heat treated steel - nitro carburized  
cover plate: high tensile aluminum

Technical data and dimensions [mm]:  
length dimensions according to DIN ISO 2768 mH

| Series | nominal clamping force [kN] | thread D* (7G) | max static load [kN] | screw in depth t <sub>min</sub> t <sub>max</sub> [mm] | weight approx. [kg] |
|--------|-----------------------------|----------------|----------------------|---|---------------------|
| MCA-S  | 40                          | M 10           | 50                   | 16 24   | 1,0                 |
|        |                             | M 12           | 70                   |   |                     |
| MCA-T  |                             | M 16           | 120                  |   |                     |
|        |                             | M 20           | 120                  |   |                     |



max. allowed temperature range: -30°C up to +90°C

## Note:

Property class of threaded bolt should be at least Q 10.9. Sizes of thread larger than M 16 should use a property class of Q 12.9, or the max. static load must be reduced. For optical control of actual screw-in depth of the T-bolt, two grooves are cut into the housing circumference matching t<sub>min</sub> and t<sub>max</sub>. When laying out the actual screw-in depth of the threaded bolt, the necessary stroke must be considered i.e. the max. specified screw-in depth must be reduced by at least the amount of the stroke.

## Application example:

MCA-T-clamping nut for adjustment of test bench sliding table



Ordering example: MCA-S - M 16 / MCA-T - M 20

# Mechanical Power Clamping Nut I Series MCA

- /// with bottomed thread // thread protected // centered operation // compact design
- /// optional fast infeed through automatic switching (locking mechanism)

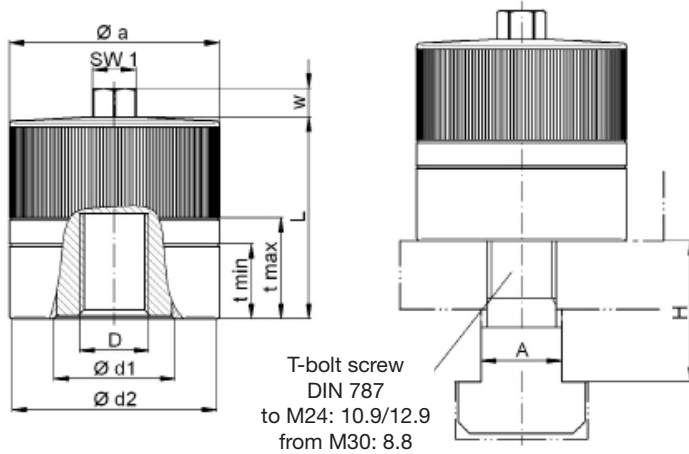

*material:*  
heat treated steel - nitro carburized  
cover plate: high tensile aluminum

Technical data and dimensions [mm]: length dimensions according to DIN ISO 2768 mH

| MCA Größe | nominal clamping force [kN] | thread D* (7G) | nominal actuation torque [Nm]** | T-Nut A | max. static load [kN] | mass approx. [kg] | Øa  | Ød1 | Ød2 | L  | screw-in depth t min max | SW1 | w  |
|-----------|-----------------------------|----------------|---------------------------------|---------|-----------------------|-------------------|-----|-----|-----|----|--------------------------|-----|----|
| 60        | 60                          | M 12           | 20                              | 14      | 70                    | 0,9               | 62  | 32  | 60  | 50 | 16/24                    | 13  | 10 |
|           |                             | M 16           | 25                              | 18      | 120                   |                   |     |     |     |    |                          |     |    |
|           |                             | M 20           | 30                              | 22      | 120                   |                   |     |     |     |    |                          |     |    |
| 100       | 100                         | M 16           | 35                              | 18      | 130                   | 1,8               | 73  | 42  | 71  | 70 | 25/35                    | 15  | 10 |
|           |                             | M 20           | 40                              | 22      | 200                   |                   |     |     |     |    |                          |     |    |
|           |                             | M 24           | 45                              | 28      | 200                   |                   |     |     |     |    |                          |     |    |
|           |                             | M 30           | 50                              | 36      | 200                   |                   |     |     |     |    |                          |     |    |
| 150       | 150                         | M 24           | 60                              | 28      | 300                   | 2,5               | 83  | 52  | 81  | 75 | 30/40                    | 17  | 12 |
|           |                             | M 30           | 70                              | 36      | 300                   | 2,4               |     |     |     |    |                          |     |    |
|           |                             | M 36           | 75                              | 42      | 300                   | 2,3               |     |     |     |    |                          |     |    |
|           |                             | M 42           | 80                              | 48      | 300                   | 2,2               |     |     |     |    |                          |     |    |
| 200       | 200                         | M 36           | 90                              | 42      | 400                   | 4,9               | 120 | 82  | 118 | 80 | 35/45                    | 19  | 12 |
|           |                             | M 42           | 110                             | 48      | 450                   | 4,8               |     |     |     |    |                          |     |    |
|           |                             | M 48           | 120                             | 54      | 450                   | 4,7               |     |     |     |    |                          |     |    |
|           |                             | M 56           | 125                             | -       | 500                   | 4,5               |     |     |     |    |                          |     |    |
|           |                             | M 64           | 135                             | -       | 500                   | 4,3               |     |     |     |    |                          |     |    |

\*property class of threaded bolt up to M 24 min. Q 10.9; from M 30 Q 8.8 (further thread sizes i.e. inches on request)  
standard thread tolerance "7G"

**Note:**

- /// For optical control of actual screw-in depth of the T-bolt, two grooves have been provided on the housing circumference matching  $t_{min}$  and  $t_{max}$ . When laying out the actual screw-in depth of the threaded bolt, the necessary stroke must be considered, i.e. the max. specified screw-in depth must be reduced at least by the amount of the stroke.
- /// The clamping forces mentioned in the data sheet can be influenced substantially by various operational parameters, such as thread length, surface quality of thread or thread lubrication.
- /// Maximum temperature range: -30°C to +200°C (optional up to +400°C)
- /// optional with locking mechanism on request

**Ordering example:**      clamping nut                      MCA 100 - M 24  
   incl. T-bolt screw                      MCA 150 - M 30 - 100 - 36

series and size \_\_\_\_\_  
thread size (T-bolt screw thread according to DIN 787) \_\_\_\_\_  
clamping height (H = 100 mm) \_\_\_\_\_  
size of T-bolt screw (A = 36 mm) \_\_\_\_\_

# Mechanical Power Clamping Nut I Series MCA-DB

- with integrated torque limiter prevents overloading of the clamping nut
- easy operation with a wrench (no torque wrench required)

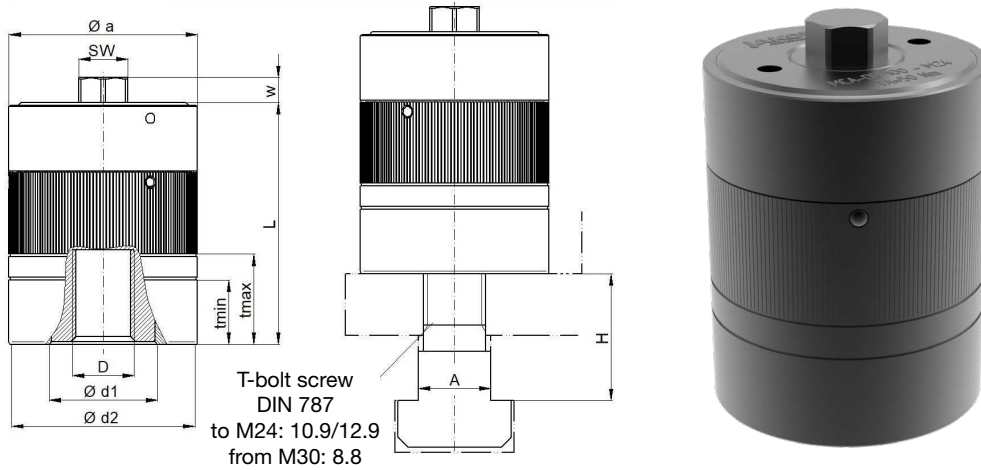

Technical data and dimensions [mm]: length dimensions according to DIN ISO 2768 mH

| MCA-DB | nominal clamping force [kN] | thread D* (7G) | disengaging moment [Nm]** | T-Nut A | max. static load [kN] | weight ca. [kg] | Øa  | Ød1 | Ød2 | L   | screw-in-depth t min max | SW | w  |
|--------|-----------------------------|----------------|---------------------------|---------|-----------------------|-----------------|-----|-----|-----|-----|--------------------------|----|----|
| 60     | 60                          | M 12           | 25                        | 14      | 70                    | 1,5             | 66  | 32  | 60  | 72  | 16 24                    | 17 | 8  |
|        |                             | M 16           | 30                        | 18      | 70                    |                 |     |     |     |     |                          |    |    |
|        |                             | M 20           | 35                        | 22      | 70                    |                 |     |     |     |     |                          |    |    |
| 100    | 100                         | M 16           | 40                        | 18      | 100                   | 2,6             | 73  | 42  | 71  | 94  | 25 35                    | 19 | 10 |
|        |                             | M 20           | 45                        | 22      | 100                   |                 |     |     |     |     |                          |    |    |
|        |                             | M 24           | 50                        | 28      | 100                   |                 |     |     |     |     |                          |    |    |
|        |                             | M 30           | 55                        | 36      | 130                   |                 |     |     |     |     |                          |    |    |
| 150    | 150                         | M 20           | 60                        | 22      | 300                   | 3,5             | 83  | 52  | 81  | 100 | 30 40                    | 19 | 10 |
|        |                             | M 24           | 65                        | 36      | 300                   |                 |     |     |     |     |                          |    |    |
|        |                             | M 36           | 80                        | 42      | 300                   |                 |     |     |     |     |                          |    |    |
|        |                             | M 42           | 85                        | 48      | 300                   |                 |     |     |     |     |                          |    |    |
| 200    | 200                         | M 36           | 100                       | 42      | 400                   | 7,4             | 120 | 82  | 118 | 110 | 35 40                    | 21 | 10 |
|        |                             | M 42           | 120                       | 48      | 400                   |                 |     |     |     |     |                          |    |    |
|        |                             | M 48           | 130                       | 54      | 400                   |                 |     |     |     |     |                          |    |    |
|        |                             | M 56           | 135                       | -       | 400                   |                 |     |     |     |     |                          |    |    |
|        |                             | M 64           | 145                       | -       | 400                   | 6,7             |     |     |     |     |                          |    |    |

\*property class of threaded bolt up to M 24 min. Q 10.9; from M 30 Q 8.8 (further thread sizes i.e. inches on request)  
standard thread tolerance "6G"

\*\* Disengaging moment is set at the factory

**Note:**

- Follow instructions for MCA
- Power clamping nuts of the MCA series can be retrofitted to the MCA-DB series by the manufacturer

|                  |                                    |   |
|------------------|------------------------------------|---|
| Ordering example | clamping nut<br>incl. T-bolt screw | MCA-DB 150 - M 36<br>MCA-DB 150 - M 24 - 100 - 28 |
|------------------|------------------------------------|---|

series and size \_\_\_\_\_  
 thread size (T-bolt screw thread according to DIN 787) \_\_\_\_\_  
 clamping height (H = 100 mm) \_\_\_\_\_  
 size of T-bolt screw (A = 36 mm) \_\_\_\_\_

# Mechanical Power Clamping Nut I Series MDA

- /// with through hole thread
- /// for variable clamping edges
- /// unlimited clamping stroke
- /// maximum clamping forces through force amplification mechanics
- /// optional quick delivery through automatic switching

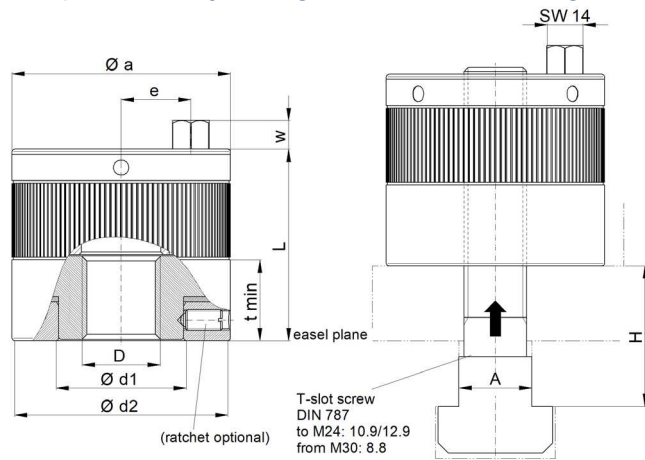

material:  
heat treated steel - nitro carburized

| MDA Size | nominal clamping force [kN] | nominal thread D* (7G) | nominal actuation torque [Nm] | max. static load [kN] | T-bolt A | weight approx. [kg] | Øa  | Ød1 | Ød2 | e    | L    | t  | hexagon socket SW** | w  |
|----------|-----------------------------|------------------------|-------------------------------|-----------------------|----------|---------------------|-----|-----|-----|------|------|----|---------------------|----|
| 60       | 60                          | M 12                   | 30                            | 70                    | 14       | 1,6                 | 74  | 40  | 72  | 21,5 | 58   | 23 | 14                  | 11 |
|          |                             | M 16                   | 35                            | 120                   | 18       | 1,6                 |     |     |     |      |      |    |                     |    |
|          |                             | M 20                   | 40                            | 120                   | 22       | 1,6                 |     |     |     |      |      |    |                     |    |
| 120      | 120                         | M 16                   | 65                            | 130                   | 18       | 2,6                 | 84  | 50  | 82  | 26,5 | 73,5 | 32 | 14                  | 11 |
|          |                             | M 20                   | 70                            | 200                   | 22       | 2,6                 |     |     |     |      |      |    |                     |    |
|          |                             | M 24                   | 75                            | 240                   | 28       | 2,5                 |     |     |     |      |      |    |                     |    |
|          |                             | M 30                   | 80                            | 240                   | 36       | 2,4                 |     |     |     |      |      |    |                     |    |
| 180      | 180                         | M 24                   | 90                            | 300                   | 28       | 4,0                 | 105 | 64  | 103 | 35   | 78   | 37 | 14                  | 11 |
|          |                             | M 30                   | 100                           | 300                   | 36       | 3,9                 |     |     |     |      |      |    |                     |    |
|          |                             | M 36                   | 110                           | 400                   | 42       | 3,8                 |     |     |     |      |      |    |                     |    |
|          |                             | M 42                   | 115                           | 450                   | 48       | 3,7                 |     |     |     |      |      |    |                     |    |
|          |                             | M 48                   | 125                           | 450                   | 54       | 3,7                 |     |     |     |      |      |    |                     |    |

\*property class of threaded bolt up to M 24 min. Q 10.9; from M 30 Q 8.8 (further thread sizes i.e. inches on request) standard thread tolerance "7G"

\*\*optional on request with hexagon socket SW8 or Torx TX50 (w=5mm)

**Note:**

- /// For optical control of minimum screw-in depth "t min" of the T-bolt, a groove has been provided on the housing circumference matching t<sub>min</sub>.
- /// Supply including t-bolt on request (see ordering example).
- /// The clamping forces mentioned in the data sheet can be influenced substantially by various operational parameters, such as thread length, surface quality of thread or thread lubrication.
- /// Maximum temperature range: -30°C to +200°C (optional up to +400°C).
- /// Locking mechanism optional on request

**Application example:** Clamping nut MDA for clamping chain wheels during milling.

**Ordering example:** clamping nut MDA 120 - M 24  
incl. T-bolt MDA 180 - M 30 - 100 - 36

series and size \_\_\_\_\_  
 thread size (T-bolt screw thread according to DIN 787) \_\_\_\_\_  
 clamping height (H = 100 mm) \_\_\_\_\_  
 size of T-bolt (A = 36 mm) \_\_\_\_\_



## Mechanical Power Clamping Nut I Series MCG

- /// with threaded pin // function as power clamping screw // centered operation // compact design
- /// integrated torque limiter possible // fast infeed through automatic switching (locking mechanism) optional

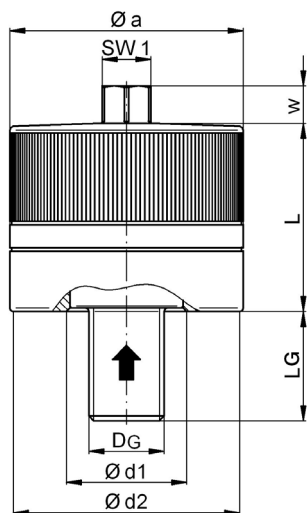

property class of threaded pin minimum 10.9

material:  
heat treated steel - nitrated

Technical data and dimensions [mm]: length dimensions according to DIN ISO 2768 mH

| MCG Size | nominal clamping force [kN] | thread DG* | nominal actuation torque [Nm] | max. static load [kN] | weight approx. [kg] | Øa  | Ød1 | Ød2 | L  | SW 1 | w  |
|----------|-----------------------------|------------|-------------------------------|-----------------------|---------------------|-----|-----|-----|----|------|----|
| 60       | 60                          | M 12       | 20                            | 70                    | 1                   | 62  | 32  | 60  | 50 | 13   | 10 |
|          |                             | M 16       | 25                            | 120                   |                     |     |     |     |    |      |    |
|          |                             | M 20       | 30                            | 120                   |                     |     |     |     |    |      |    |
| 100      | 100                         | M 16       | 35                            | 130                   | 2                   | 73  | 42  | 71  | 70 | 15   | 10 |
|          |                             | M 20       | 40                            | 200                   |                     |     |     |     |    |      |    |
|          |                             | M 24       | 45                            | 200                   |                     |     |     |     |    |      |    |
| 150      | 150                         | M 30       | 50                            | 200                   | 3                   | 83  | 52  | 81  | 75 | 17   | 12 |
|          |                             | M 24       | 60                            | 300                   |                     |     |     |     |    |      |    |
|          |                             | M 30       | 70                            | 300                   |                     |     |     |     |    |      |    |
| 200      | 200                         | M 36       | 75                            | 300                   | 6                   | 120 | 82  | 118 | 80 | 19   | 12 |
|          |                             | M 42       | 80                            | 300                   |                     |     |     |     |    |      |    |
|          |                             | M 36       | 120                           | 400                   |                     |     |     |     |    |      |    |
|          |                             | M 42       | 125                           | 450                   |                     |     |     |     |    |      |    |
|          |                             | M 48       | 130                           | 450                   |                     |     |     |     |    |      |    |
|          |                             | M 56       | 140                           | 500                   |                     |     |     |     |    |      |    |
|          |                             | M 64       | 150                           | 500                   |                     |     |     |     |    |      |    |

length of threaded pin  $L_G$  = variable (according to customer information)

\*further thread sizes i.e. inches on request

max. allowed temperature range: -30°C up to +200°C

**Note:**

- /// special designs with torque limitation are possible on request (technical data see series MCA-DB)

Ordering example: clamping nut MCG 100 - M 24 -  $L_G=120$

series and size (max. clamping force = 100 kN) \_\_\_\_\_

thread size \_\_\_\_\_

thread length \_\_\_\_\_

# Mechanical Power Clamping Nut I Series MDR

- /// side operation
- /// low profile
- /// with through-hole thread
- /// optional quick delivery through automatic switching (locking mechanism)

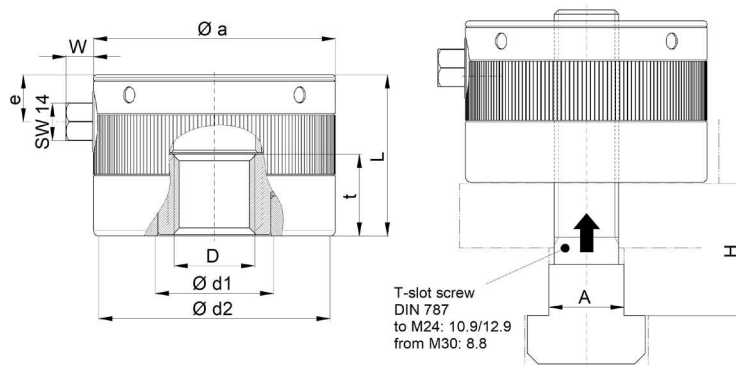

Technical data and dimensions [mm]: length dimensions according to DIN ISO 2768 mH

| MDR Size | nominal clamping force [kN] | thread D* (7G) | max. actuation torque [Nm] | T-Nut A | max. static load [kN] | weight approx. [kg] | Øa  | Ød1 | Ød2 | e    | L  | t  | W  |
|----------|-----------------------------|----------------|----------------------------|---------|-----------------------|---------------------|-----|-----|-----|------|----|----|----|
| 120      | 120                         | M 16           | 85                         | 18      | 130                   | 2,2                 | 90  | 44  | 86  | 17,5 | 60 | 30 | 10 |
|          |                             | M 20           | 90                         | 22      | 200                   |                     |     |     |     |      |    |    |    |
|          |                             | M 24           | 95                         | 28      | 240                   |                     |     |     |     |      |    |    |    |
|          |                             | M 30           | 105                        | 36      | 240                   |                     |     |     |     |      |    |    |    |
| 150      | 150                         | M 24           | 90                         | 28      | 300                   | 4,2                 | 120 | 52  | 115 | 17,5 | 65 | 35 | 10 |
|          |                             | M 30           | 100                        | 36      | 300                   | 4,1                 |     |     |     |      |    |    |    |
|          |                             | M 36           | 110                        | 42      | 300                   | 4,0                 |     |     |     |      |    |    |    |
|          |                             | M 42           | 125                        | 48      | 300                   | 3,9                 |     |     |     |      |    |    |    |

\*property class of threaded bolt up to M24 min. Q 10.9; from M30 Q 8.8 (further thread sizes i.e. inches on request)  
standard thread tolerance „7G“  
max. allowed temperature range: -30°C up to +200°C

**Note:**

- /// Locking mechanism optional on request

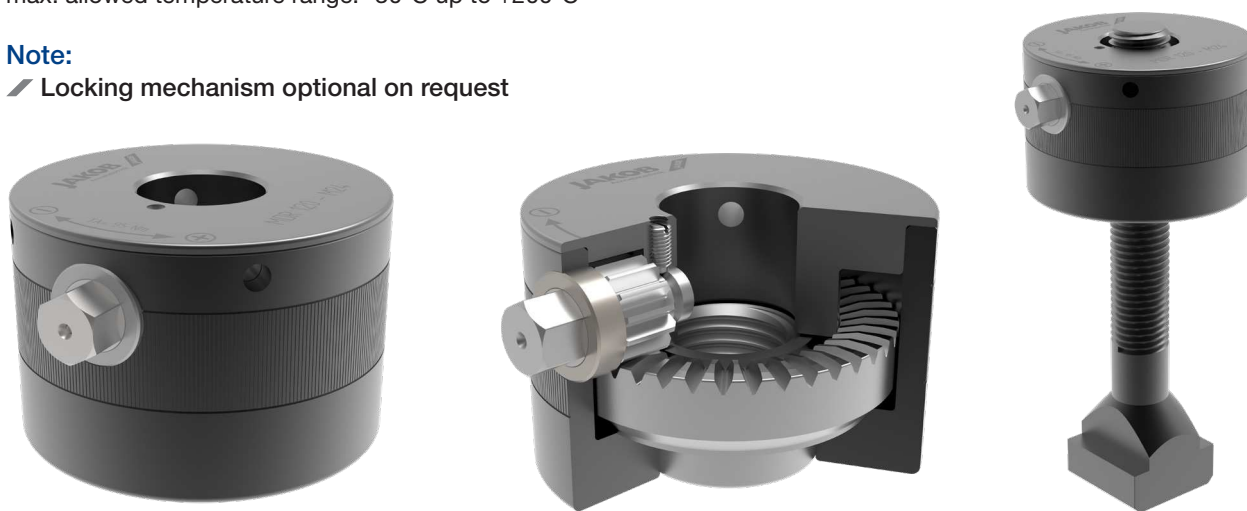

ordering example:

Clamping nut  
Incl. T-slot screw

MDR 150 - M 36  
MDR 120 - M 30 - 100 - 36

series and size

thread size (T-slot screw thread according to DIN 787)

clamping height (H=100)

groove width (A=36 mm)

## Videolinks | Clamping Elements

Here you can find videos of some of the products of the JAKOB clamping elements range from our Video channel. Scan the QR code with a suitable app to get directly to the respective video. These and other videos can also be found on our website.



Youtube -  
Channel of JAKOB  
Antriebstechnik GmbH



Foto: Talsabell CA

### Power Clamping Nut MCA



### Power Clamping Screw SC

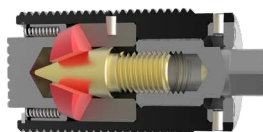

### Power Clamping Nut MDA



### Power Clamping Screw MSP/MSPD

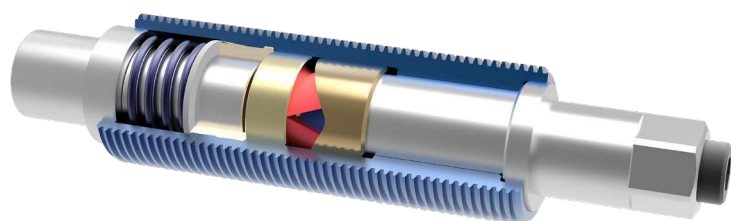

# Power Clamping Screws

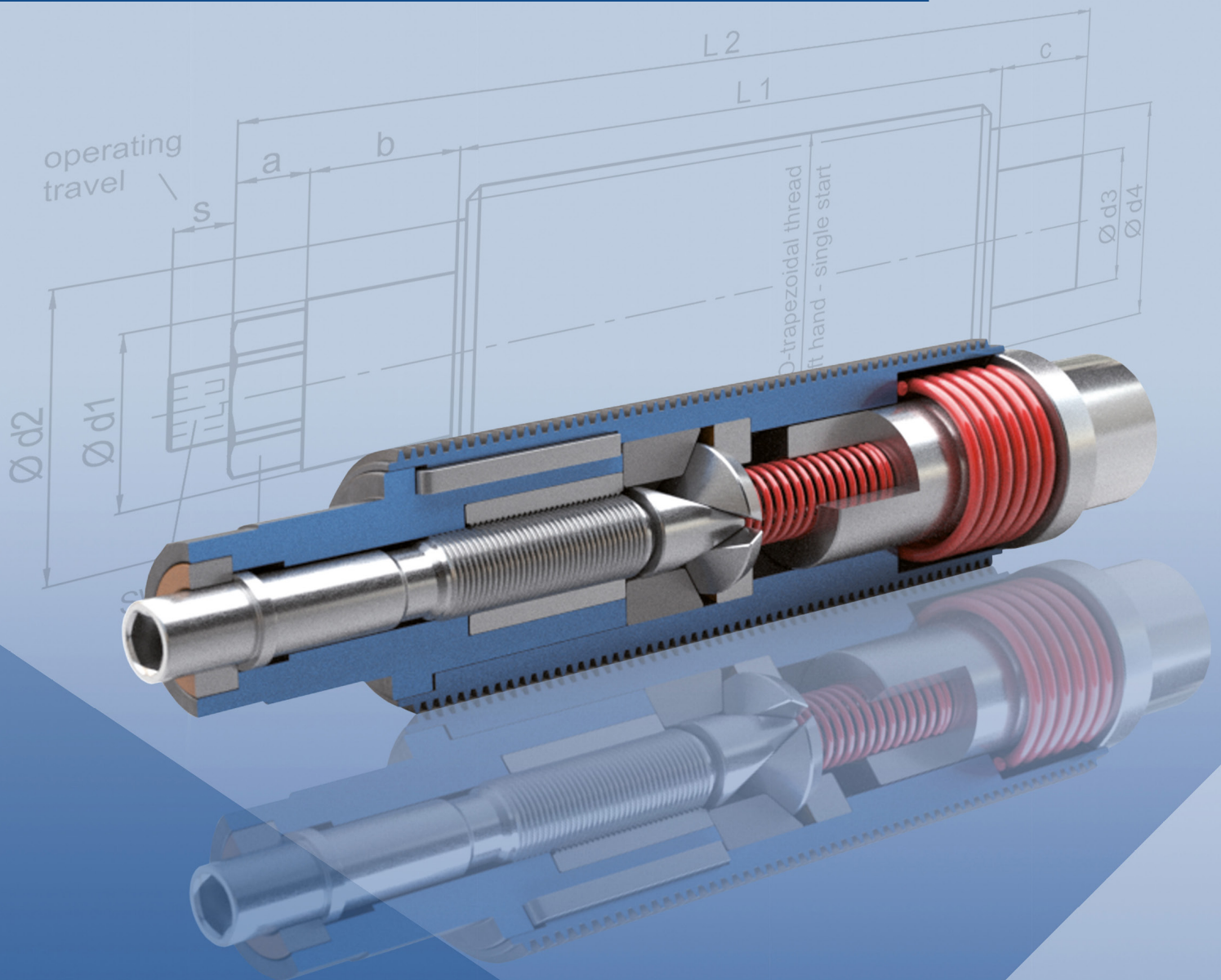

## Mechanical Power Clamping Screw I Series SC

- /// wedge mechanism as force amplifier
- /// high clamping forces
- /// maximum operational safety
- /// low actuation torque
- /// simple & manual operation

The power clamping screws of the SC series are equipped with a wedge system as force amplifier. This innovative system allows for highest clamping forces with low actuation torques and simple manual operation. The robust design of all parts, the self-locking mechanism as well as a high overload capability guarantee maximum operational safety. The clamping screws of the SC series have various application possibilities, mainly in presses, punches and machine tools, as well as in jigs, fixtures and similar devices.

### Function:

The wedge clamping system of the SC clamping screw is self-locking in each clamping position due to its geometry and offers a clamping stroke of up to 3 mm. This way, depending on the actuation torque, very high clamping forces up to the nominal clamping force can be achieved.

### Clamping procedure:

The infeed of the clamping screw down to a solid contact with the part to be clamped (7) is the first step, done by manually turning the housing (1) clockwise. Only then, the hexagon of the actuation spindle (2) should be turned clockwise, thus moving the forced-in key (3) in axial direction and pressing the wedge parts (4) in radial direction. The latter motion results in the axial stroke of the thrust piece (5) against the workpiece (7). The clamping force is led over the wedge bearing (6) through the housing (1) into the clamping device (8).

After approximately two turns of the actuation hexagon the travel of the thrust piece will be blocked by an internal fixed stop and the torque wrench will disengage although the required clamping force has not been generated; the clamping operation has to be repeated. The clamping stroke state is indicated by the operating path "s". The maximum clamping position is reached when the lower cylindrical portion of the actuation hexagon is even with the top of the housing (Fig. A2).

### Release:

The release procedure is carried out in reverse order. By turning the operating hexagon to the left up to the fixed back stop (Fig. A1), the wedge slide moves back and the clamping mechanism is released. Coil springs push the pressure piece and the wedges back into the starting position.

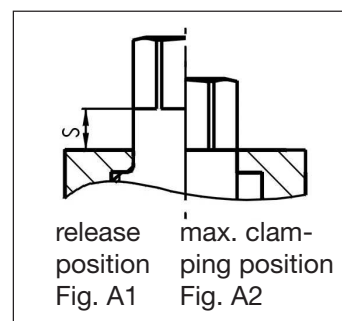
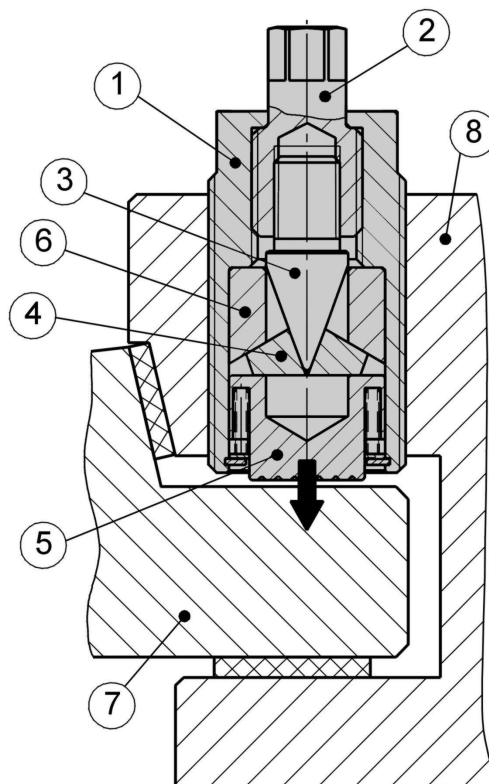

## Mechanical Power Clamping Screw I Series SC

Technical data and dimensions [mm]: length dimensions according to DIN ISO 2768 mH

| SC<br>Size | nominal<br>clamping<br>force<br>[kN] | max.<br>actuation<br>torque<br>[Nm] | max.<br>clamping<br>stroke<br>[mm] | max.<br>static<br>load<br>[kN] | operating<br>path<br>s<br>[mm] | mass<br>approx.<br>[kg] | thread<br>D* (6g) | Ø d | L1  | L   | SW 1 | SW 2 |
|------------|--------------------------------------|-------------------------------------|------------------------------------|--------------------------------|--------------------------------|-------------------------|-------------------|-----|-----|-----|------|------|
| 36         | 40                                   | 30                                  | 1,5                                | 80                             | 5                              | 0,5                     | M 36 x 3          | 19  | 62  | 73  | 13   | 30   |
| 48         | 100                                  | 70                                  | 2,2                                | 160                            | 7,5                            | 1,1                     | M 48 x 3          | 28  | 75  | 90  | 17   | 41   |
| 64         | 150                                  | 120                                 | 2,5                                | 250                            | 8,5                            | 2,5                     | M 64 x 4          | 39  | 90  | 110 | 19   | 55   |
| 80         | 200                                  | 140                                 | 2,5                                | 300                            | 8,5                            | 5,3                     | M 80 x 4          | 39  | 100 | 160 | 19   | 65   |
| 100        | 250                                  | 130                                 | 3                                  | 400                            | 17                             | 12                      | TR 100 x 6        | 60  | 205 | 230 | 14** | 65   |

\*further sizes and threads (inch thread) available on request

allowed temperature range: -40°C up to +250°C

\*\*hexagon socket - operating pin length: s = 17 mm

### Note:

- to ensure the required clamping force is achieved and to protect the internal mechanism from damage, we recommend the use of a torque wrench for applying the actuation torque. Under certain conditions, clamping is also acceptable with a standard wrench or socket wrench.
- the clamping screws are lubricated for life and maintenance free under normal operating conditions. A high temperature version of up to 400°C is possible.

*material:*

heat treated steel - nitro carburized

### Application example: slide-in-clamp

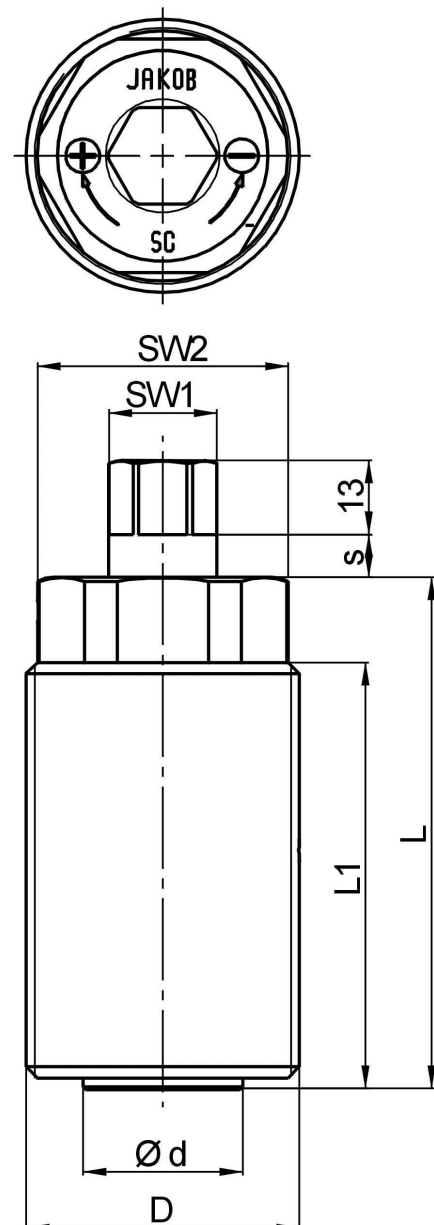
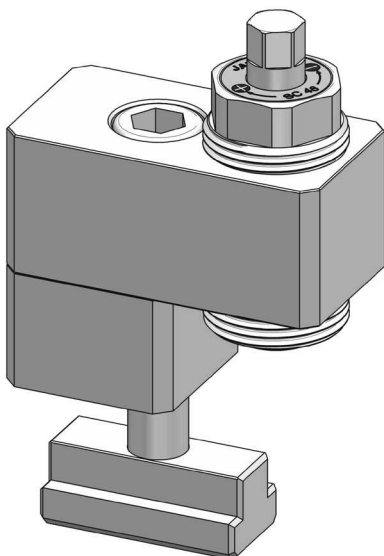

## Power Clamping Screws | Series MSP/MSPD-HSP

For face plates and surface plates on jaw boxes as well as grinding and turning machines and special machines

JAKOB power clamping screws have been developed for the highest demands and maximum workpiece weights with optimum operational safety. They are primarily suited for integration in jaw boxes or for direct installation in face plates of lathes, grinding and special machines. Diverse clamping screw series with different constructions and profile requirements are available. The user can choose between hydraulic or mechanical and single or double actuating designs.

All parts are made of heat-treated steel and produced with high precision. This guarantees a clamping element with highest sturdiness and reliability.

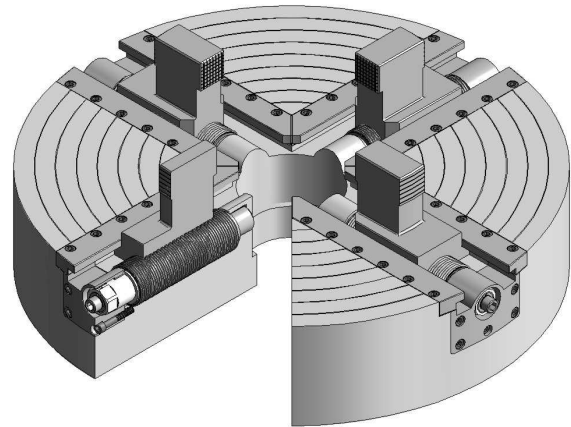

### Essential features of performance:

- /// enormous clamping force // low actuation torque
- /// maximum reliability // high stiffness
- /// large clamping stroke // high alignment accuracy
- /// simple & manual operation
- /// minimum maintenance

### Application examples:



Face plate for turning center with 8 power clamping screws type MSP 200 for clamping of turbine rotors up to 350 metric tons total weight

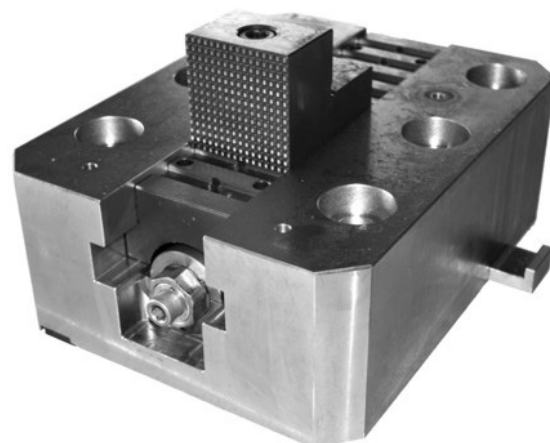

Double actuating power clamping screw series MSPD 80 for clamping direction internal and external integrated in jaw box

# Power Clamping Screws | Series MSP/MSPD-HSP

## Mechanical Power Clamping Screw Series MSP / MSPD

The force transmission in the mechanical power clamping screws is generated by a special mechanical key clamping system. The sophisticated geometry of the key mechanics have very large transmission surfaces and a self-locking mechanism to ensure low wear and the highest reliability. Especially worth mentioning is the double-acting version, series MSPD, with a simple automatic reverser to change clamping direction from external to internal clamping. Furthermore, its simple, manual operation and low installation cost are relevant. When taking the main technical and economic assessment criteria into consideration, the MSP/MSPD series can be recommended as the ideal version for most applications.

## Hydromechanical Power Clamping Screw Series HSP

The hydromechanical power clamping screw's operating principle is based on power amplification, resulting from the area ratio of a primary and secondary piston. In the distinctly smaller primary piston, an internal oil pressure of up to 600 bar is generated and at the same time a long stroke distance is travelled. The secondary piston, with its larger effective area with smaller clamping stroke produces an extremely large axial force, which is transmitted through the external thread to the piston housing on the clamping shoe. HSP power clamping screws are only provided for external clamping direction. They excel with their long clamping strokes and low actuation torques. However, due to the necessary, mechanical safeguard (counter ring), significantly higher expenses are to be expected.

### Note:

- during calculation of installation length L1 bearing rings or axial washers must be taken into account
- basically, except the fitting position L1, the thread of the screw housing or the dimensions of the bearing pin can be customised to fit customer needs. That might be necessary, especially when replacing defective older model clamping screws and when retrofitting machine tools. Please get in touch with us if you have variances from standard dimensions.
- clamping force monitoring can be integrated using our additionally available Force Monitoring System (FMS). See page 22 for more information
- operating tools as well as hydraulic load cells for force monitoring available upon request

## Clamping Force Diagram

Each clamping screw is supplied with a clamping force diagram and a test report.

On request, the appropriate clamping force diagram can be supplied on an aluminum plate for fitting to the machine, as available information for the operating personnel. Due to friction loss in the clamping jaws or linear guides, the table or diagram values for the actuation torque must be corrected. The appropriate factor must be determined, if necessary, by the face plate or jaw box manufacturers either empirically or based on trials and tests.

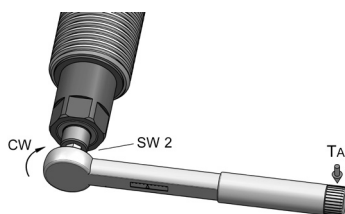

Clamping force diagram "MSPD 120"

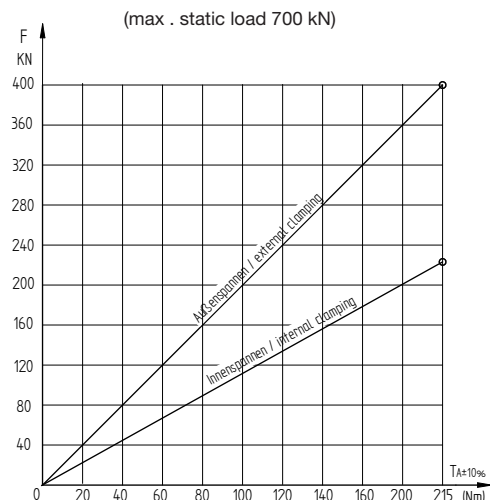

## Mechanical Power Clamping Screws I Series MSP/MSPD

### Design and function

The single acting Mechanical Power Clamping Screws of the MSP series have been developed for external clamping only, whereas the double acting ones of the MSPD series are designed for external (shafts, rollers) as well as internal clamping (pipes, bushes). These mechanical power clamping screws are equipped with a wedge mechanism system as force amplifier. The double acting version is equipped with an automatic mechanism to change clamping direction. This system generates high clamping forces with a simple operating procedure requiring low manual actuation torque. The state of the art wedge mechanism system is extremely robust and self-locking in every clamping stage. The high stiffness achieved thus also increases operational safety. No additional mechanical safety devices or supports are required for supporting the threaded power clamping screws.

The force amplification mechanic is activated through rotation of the drive spindle, which presses the threaded spindle and jaw against the workpiece. Clamping force is generated according to actuation torque. By changing the load direction from "external" to "internal", the clamping direction within the force magnifier automatically changes without the need to undertake an additional reversal of the clamping direction by hand. Correspondingly, the clamping forces are passed on further; depending on the direction of clamping into the left bearing journal (LH) during external clamping, or in the right bearing journal (RH) during internal clamping. The reverse motion of the force amplifier and threaded power clamping screw is compensated by a compression spring which also functions as a return spring during unclamping.

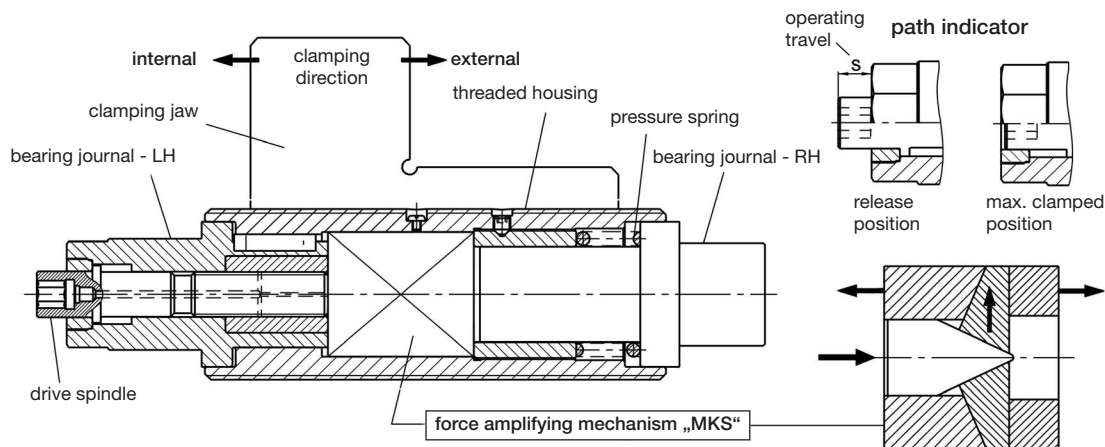

### Operation:

#### External clamping

The clamping jaw is prealigned and pretensioned by turning the external hexagon SW1 clockwise. A torque wrench should be used for force clamping and fine adjustment. By turning the internal hexagon SW2 clockwise, the drive spindle's force amplification is activated and clamping force is generated proportionally to the actuation torque until the torque wrench disengages upon reaching the preselected torque (see clamping force diagram). The clamping stroke can be controlled via an operating path indicator. The clamping procedure has to be repeated by loosening SW2 and pretensioning SW1 if the preselected starting torque has not been reached at the end of the operating path. Avoid exceeding the maximum actuating torque as it may cause damage.

#### Internal clamping

The clamping jaw approaches the workpiece is prealigned and pretensioned by turning the external hexagon SW1 counter-clockwise. This automatically changes the clamping direction to internal clamping. For this changeover the threaded housing of the power clamping screw with the jaw is maintained in a preloaded state and then subjected to an axial motion in reverse direction, i.e. the external hexagon SW1 should be turned by approx. one turn extra. The power clamping with internal hexagon SW2 is then done in a similar manner as the external clamping procedure.

#### Release

Release is effected in reverse order by turning the internal hexagon SW2 counter-clockwise until the fixed stop. The drive spindle is reversed and the clamping system unclamped. The return spring pushes the threaded spindle with clamping jaw back, the force amplifier returns to its initial position.

# Mechanical Power Clamping Screws | Series MSP/MSPD

Series MSP - Mechanical Power Clamping Screw for clamping direction “external”

Series MSPD - Mechanical Power Clamping Screw for clamping directions “internal and external”

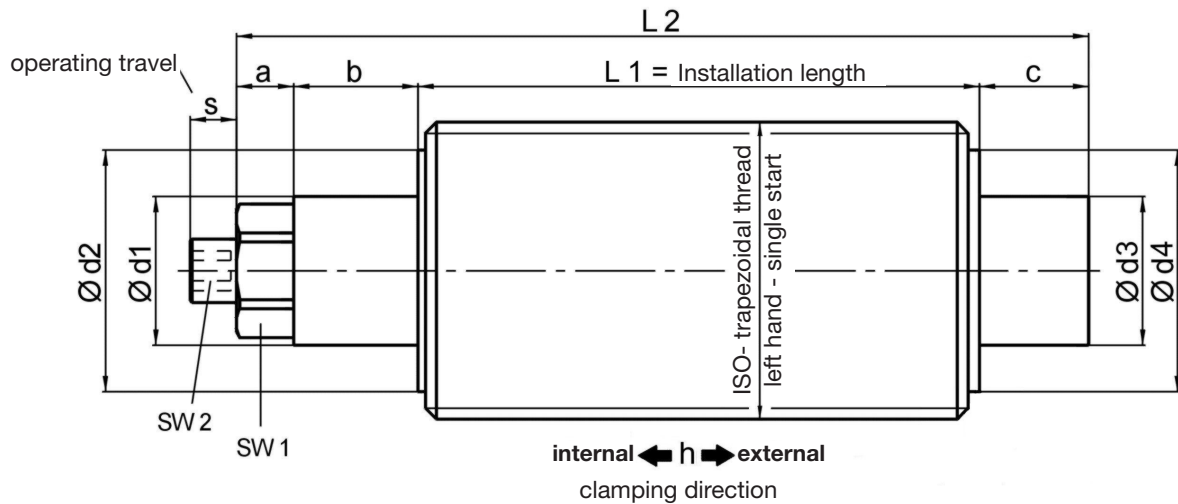

material:

heat treated steel - nitro carburized

Technical data and dimensions [mm]: length dimensions according to DIN ISO 2768 mH

| MSP/MSPD                      | Size          | 50   | 65    | 80   | 100   | 120   | 160   | 200    |
|-------------------------------|---------------|------|-------|------|-------|-------|-------|--------|
| ISO-trapezoidal thread        | TR-left       | 50x3 | 65x4  | 80x5 | 100x6 | 120x6 | 160x8 | 200x10 |
| nominal clamping force [kN]   | external      | 100  | 180   | 220  | 270   | 400   | 500   | 600    |
|                               | internal      | 70   | 120   | 150  | 190   | 290   | 370   | 480    |
| nominal actuation torque [Nm] |               | 60   | 70    | 100  | 130   | 215   | 200   | 220    |
| max. static load [kN]         |               | 150  | 250   | 300  | 400   | 700   | 1100  | 1800   |
| stroke h [mm]                 |               | 2    | 2,5   | 3    | 3     | 3     | 3     | 3      |
| operating travel s [mm]       |               | 7,5  | 15    | 17   | 17    | 17    | 25    | 27     |
| hexagon                       | external SW 1 | 27   | 41    | 46   | 50    | 55    | 65    | 85     |
|                               | internal SW 2 | 10   | 12    | 14   | 14    | 17    | 17    | 17     |
| a                             |               | 20   | 20    | 20   | 25    | 25    | 30    | 40     |
| b / c                         |               | 30   | 35    | 40   | 50    | 60    | 70    | 80     |
| Ø d1/d3 f7                    |               | 30   | 45/40 | 50   | 60    | 65    | 80    | 100    |
| Ø d2/d4                       |               | 40   | 55/52 | 68   | 85    | 95    | 130   | 160    |
| MSPD - L1 min.                |               | 150  | 170   | 230  | 250   | 280   | 330   | 360    |
| MSPD - L2 min.                |               | 230  | 260   | 330  | 375   | 425   | 500   | 560    |
| MSP - L1 min.                 |               | 140  | 150   | 210  | 220   | 250   | 290   | 320    |
| MSP - L2 min.                 |               | 220  | 240   | 310  | 345   | 395   | 460   | 520    |

Note: / special thread sizes or customized dimensions are possible upon request

Ordering example: MSPD 100 - TR 100 x 6 - LH - L1 = 300 mm

# Hydromechanical Power Clamping Screws I Series HSP

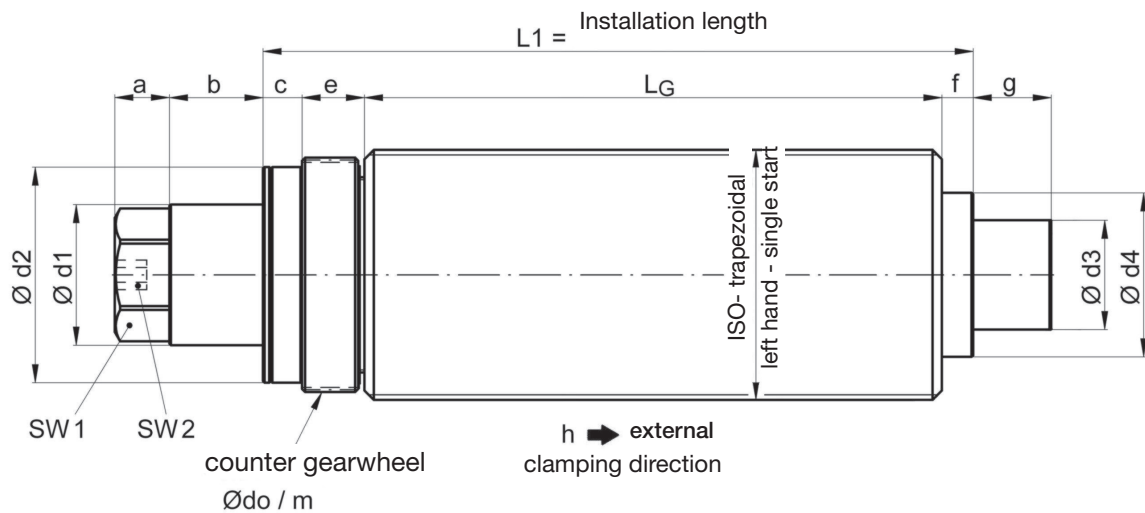

**material:**  
heat treated steel nitro carburized

Technical data and dimensions [mm]: length dimensions according to DIN ISO 2768 mH

| HSP                      | size          | 80      | 100      | 120      | 160      | 200       | 220      |
|--------------------------|---------------|---------|----------|----------|----------|-----------|----------|
| ISO-trapezoidal thread   | left          | TR 80x5 | TR 100x6 | TR 120x6 | TR 160x8 | TR 200x10 | TR220x10 |
| nominal clamping force   | [kN]          | 100     | 150      | 220      | 400      | 600       | 750      |
| nominal actuation torque | [Nm]          | 60      | 70       | 80       | 150      | 150       | 140      |
| max. static load         | [kN]          | 200     | 300      | 400      | 700      | 1000      | 1200     |
| stroke h                 | [mm]          | 3       | 3        | 5        | 6        | 6         | 8        |
| operating path s         | [mm]          | 16      | 19       | -        | -        | -         | -        |
| hexagon                  | external SW 1 | 46      | 50       | 65       | 75       | 85        | 100      |
|                          | internal SW 2 | 12      | 14       | 17       | 17       | 17        | 17       |
| a                        |               | 20      | 25       | 30       | 35       | 40        | 45       |
| b                        |               | 30      | 40       | 50       | 60       | 70        | 70       |
| c                        |               | 13      | 15       | 20       | 25       | 30        | 30       |
| Ø do                     |               | 71,5    | 90       | 108      | 146      | 184       | 201      |
| module m                 |               | 1,25    | 1,5      | 1,5      | 2        | 2         | 3        |
| Ø d1 f7                  |               | 50      | 60       | 75       | 90       | 100       | 120      |
| Ø d2                     |               | 68      | 85       | 100      | 140      | 165       | 180      |
| Ø d3 f7                  |               | 40      | 50       | 60       | 70       | 80        | 100      |
| Ø d4                     |               | 60      | 80       | 90       | 105      | 135       | 150      |
| e                        |               | 22      | 25       | 30       | 40       | 45        | 45       |
| f                        |               | 15      | 15       | 15       | 20       | 20        | 20       |
| g                        |               | 30      | 35       | 40       | 50       | 55        | 60       |
| LG min.                  |               | 140     | 145      | 215      | 230      | 300       | 455      |
| L1 min.                  |               | 190     | 200      | 280      | 315      | 395       | 550      |

- Note:
- after completion of the clamping procedure the clamping screw should be secured against overload by means of a mechanical safety device (counter gearwheel), which as well helps to achieve a high degree of stiffness
  - special thread sizes or customized dimensions as well as different toothing of counter gearwheel or series with higher clamping force are available on request
  - the pinion shaft for driving the counter gearwheel is not supplied

Ordering example: HSP 100 - TR 100 x 6 - lh - L1 = 300 mm

## Force Monitoring

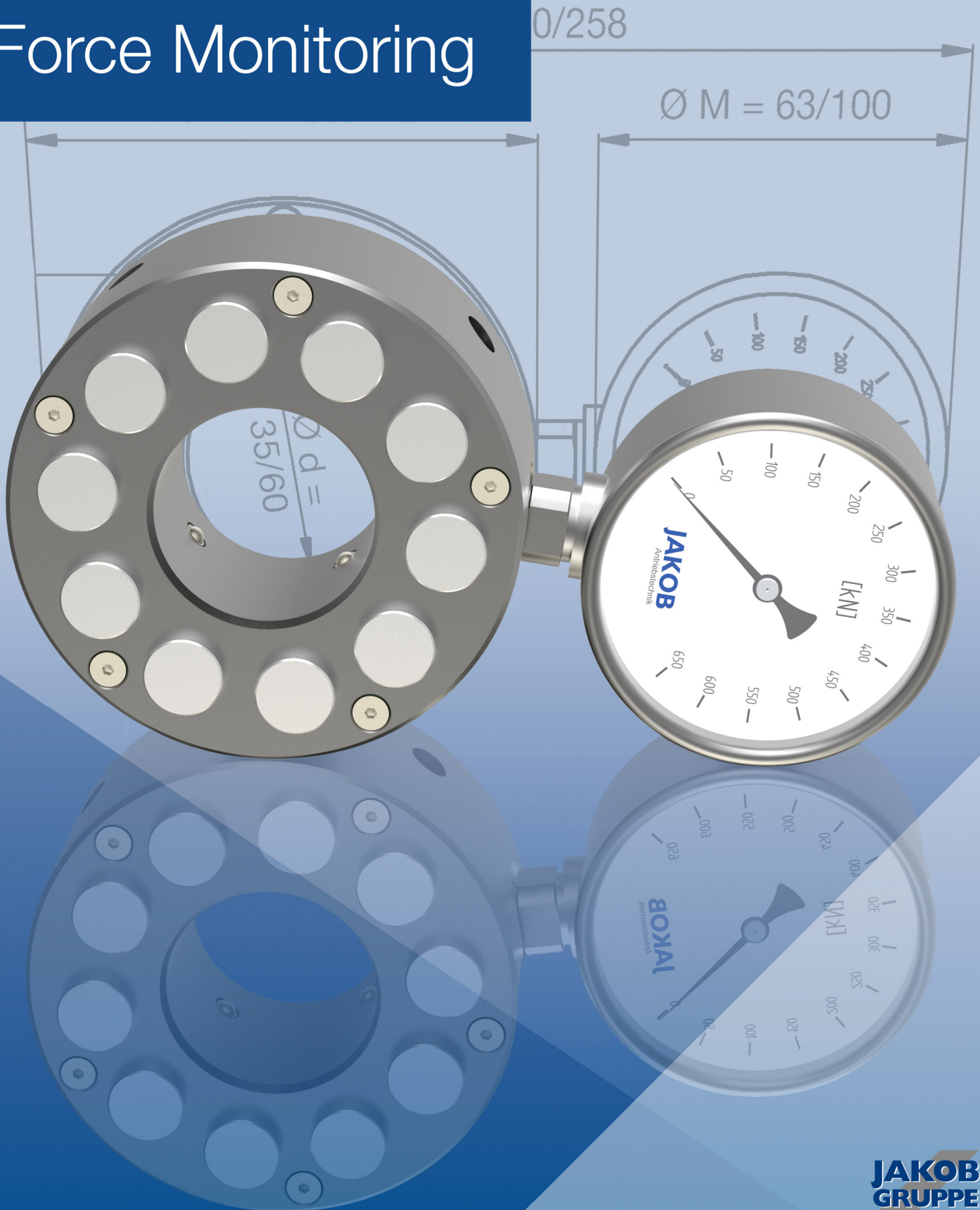

## HMD - Hydraulic Force Measuring System

| type-size             | HMD 300-R     | HMD 600-R  |
|-----------------------|---------------|------------|
| measuring range       | 0 - 300 kN    | 0 - 600 kN |
| scale graduation      | 10 kN         | 10 kN      |
| accuracy [T=20°C]     | 1,6%          | 1,0%       |
| mass                  | 3,5 kg        | 6,2 kg     |
| temperature range     | -10°C - +60°C |            |
| protection class      | IP 65         |            |
| maximum piston stroke | 1mm           |            |

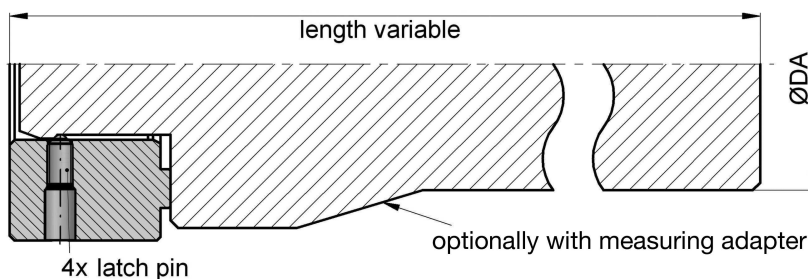
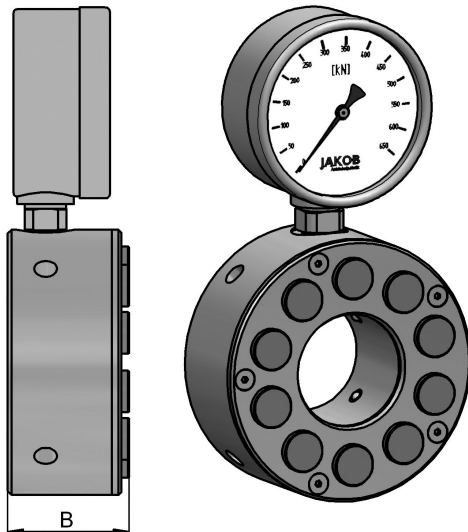
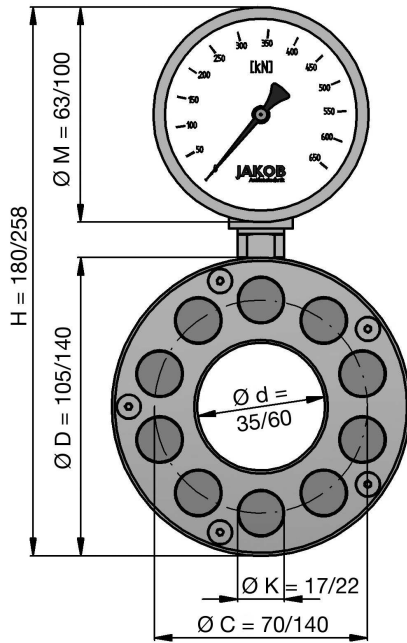

### General:

Hydraulic load cells of the series HMD are robust indicators that calculate axial compressive forces with median accuracy. The force is transferred analogously over pressure pistons and the hydraulic fluid to a manometer with a kN-indicator scale. The measuring system is autarkic, so there is no need of external or additional energy. Therefore static and dynamic forces can be detected at numerous applications of the entirety of mechanical engineering in an easy and economically priced way.

### System design - function:

The load cells are designed on the basis of the multi-piston-system. The compressive forces are transferred over several small pistons to the hydraulic fluid. In the series HMD-R which is in ring forms the pistons are arranged concentrically. The innovative principle allows the realization of load cells in every geometric configuration. The floating piston-overlay compensates construction and angle mistakes in a considerable dimension. High shearing forces should be avoided. Special piston seals guarantee an enduring and hermetic sealing of the fluid medium.

### Notice:

During the measuring, ensure that all pistons are pending the measuring surface with the complete pressure load area.

To ensure a flawless measuring function, the manometer-connection and the lock or fill screw should not be removed. Load cells are useless for measuring strong pulsating forces or high accelerations.

The inner diameter of the ring load cells is primed for the insertion of measuring adapter pieces using four ball latch pins. Customized adapter types are available on request (see example of use).

## Spring Clamping Cylinders

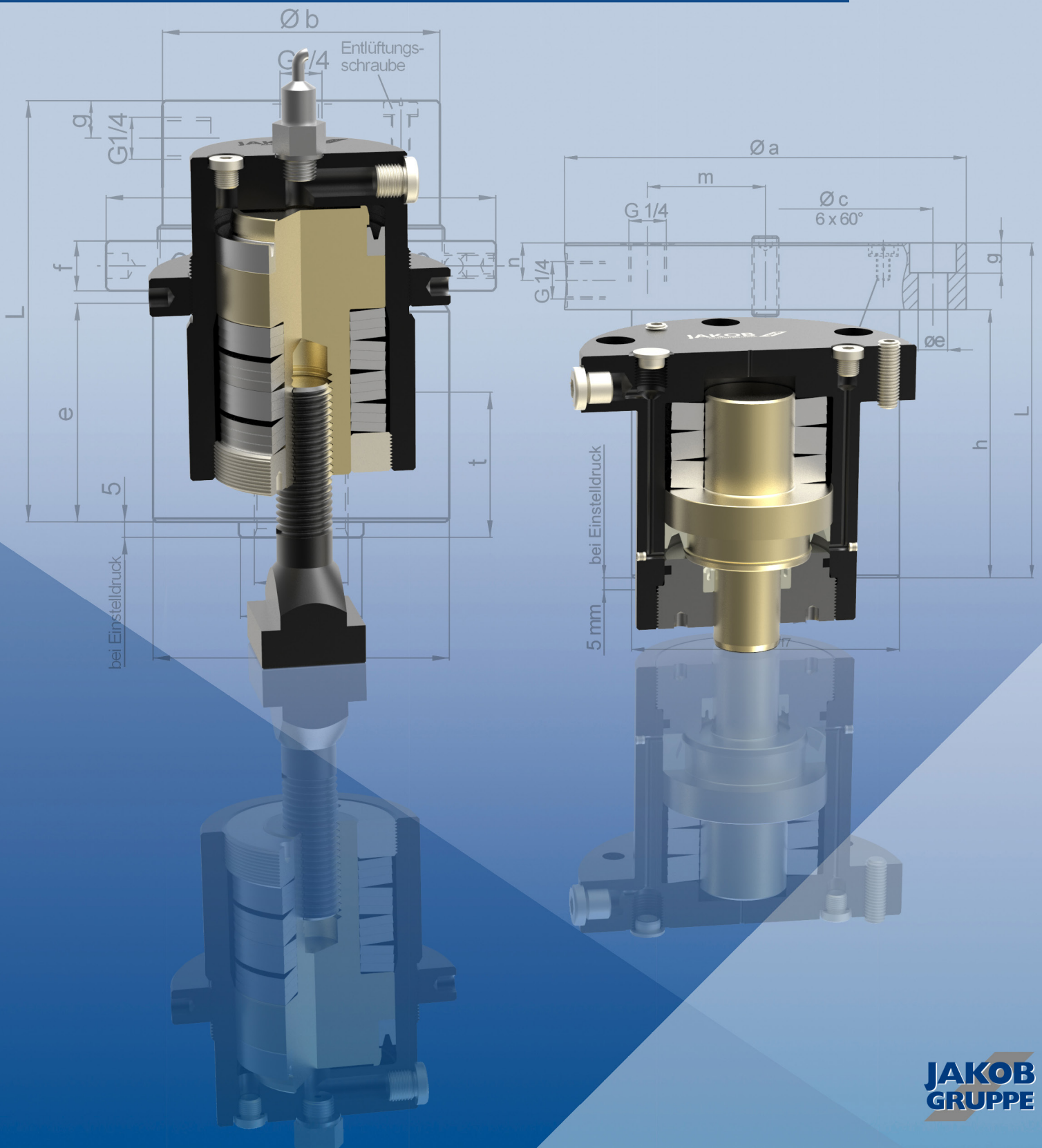

## Hydromechanical Spring Clamping Systems I Series ZSF/ZDF

- /// mechanical clamping - hydraulic releasing
- /// high operational safety
- /// leak-proof and robust
- /// economical clamping solution

### General

Hydromechanical spring clamping systems work through interaction of mechanical and hydraulic systems. The clamping force is applied mechanically through a pre-loaded disk spring packet.

The two types are provided as spring clamping or spring pressure cylinders. The hydraulic pressure is only required for the release stroke during which the tie rod or thrust pin is lifted. This system guarantees the greatest reliability because the clamping force is maintained fully independent of the oil pressure or leak-losses. With the hydraulic unit's short operating times, this system is also cost-effective. The spring clamping cylinders of the ZSF and ZDF series provide sturdy and reliable clamping elements that can be used wherever sliding and movable machine parts need to be clamped or locked temporarily. Other applications are fixture construction and workpiece or tool clamping.

### Operational principle

The thrust or draw piston is pressurised reciprocally by the disk spring packet or hydraulic pressure. The spring packet is compressed with increasing oil pressure; the spring force increases. Under pressure, the corresponding nominal clamping force is reached as a reaction force of the disk spring packet. To release the thrust or draw piston, a higher hydraulic pressure is required, which, up to a maximum value, is proportional to the release stroke. The setting pressure is required only for precise force adjustment during initial installation. During the actual operating cycle, the cylinders are either pressureless or at release pressure. The corresponding pressure values can be seen in the spreadsheet.

In ZSF series spring clamping cylinders, a mandrel or a tie rod is threaded down and secured in the draw piston's thread hole (available on request as single piece or with special thread). The draw piston is protected against incorrect installation with a pin connection.

### Assembly and adjustment

- /// to operate, a hydraulic unit is needed which should be equipped with a manometer, a pressure cut-off valve, a solenoid valve and a pressure switch unit
- /// fill the cylinders and lines at low pressure and bleed (cylinders are supplied unfilled)
- /// increase system pressure to the set pressure and maintain; align cylinder using the ring guide nut (ZSF), setscrews (ZDF-u) or fitting discs (ZDF-o) until the thrust piston or the clamp is free from play; fasten thrust piston with screws or secure the ring guide nut on the clamping cylinder
- /// release system pressure; set release pressure for the required release stroke; check the release stroke and adjust if necessary

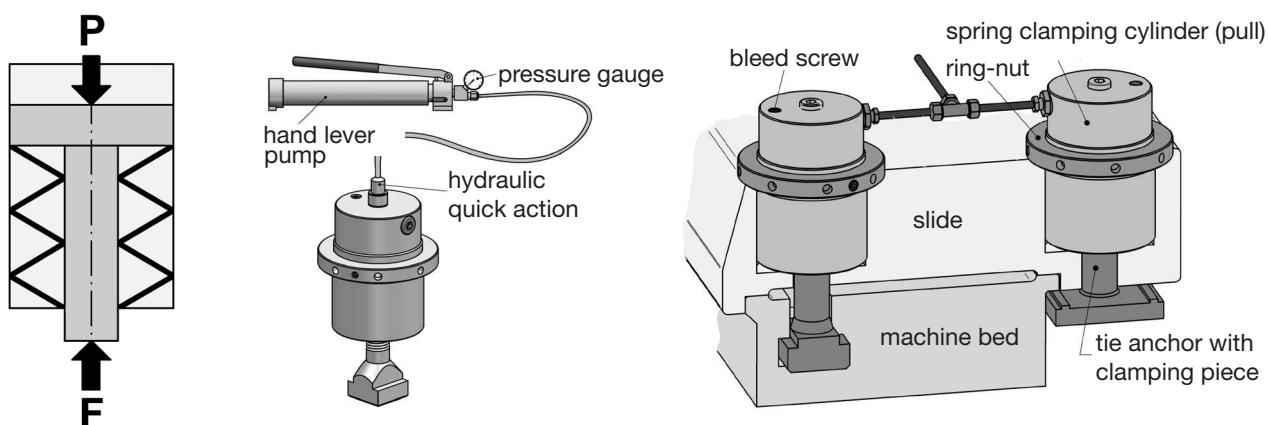

**Note:** If automatic clamping operation is not required, the temporary, manual hydraulic connection to a manually operated piston pump with a pressure gauge provides a cost effective alternative (see fig. at left).

# Spring Clamping Cylinder I Series ZSF

## Technical data:

| ZSF Size | nominal clamping force [kN] | adjusting pressure [bar] | max release stroke [mm] | release pressure at 0,5 mm stroke [bar] | release pressure at 1,0 mm stroke [bar] | release pressure at max stroke [bar] | stroke volume at 1 mm stroke [cm <sup>3</sup> ] | mass approx. [kg] |
|----------|-----------------------------|--------------------------|-------------------------|---|---|--------------------------------------|---|-------------------|
| 1.600    | 16                          | 135                      | 2,0                     | 170                                     | 210                                     | 290                                  | 1,3   | 2,0               |
| 2.500    | 25                          | 135                      | 1,6                     | 160                                     | 185                                     | 230                                  | 2,0   | 3,0               |
| 4.000    | 40                          | 150                      | 2,0                     | 170                                     | 190                                     | 240                                  | 2,8   | 4,5               |
| 6.300    | 63                          | 175                      | 1,5                     | 190                                     | 210                                     | 235                                  | 3,8   | 6,8               |
| 10.000   | 100                         | 210                      | 1,5                     | 250                                     | 280                                     | 320                                  | 5,0   | 8,5               |
| 16.000   | 160                         | 210                      | 1,2                     | 240                                     | 275                                     | 295                                  | 7,9   | 21                |
| 20.000   | 200                         | 210                      | 1,2                     | 240                                     | 270                                     | 290                                  | 11,3  | 26,5              |
| 25.000   | 250                         | 190                      | 1,6                     | 210                                     | 235                                     | 260                                  | 14,3  | 41                |
| 35.000   | 350                         | 190                      | 1,0                     | 210                                     | 230                                     | 230                                  | 20,1  | 60                |

temperature range: -30°C up to +100°C – mounting position: discretionary



update version

material:  
heat-treated steel, burnished

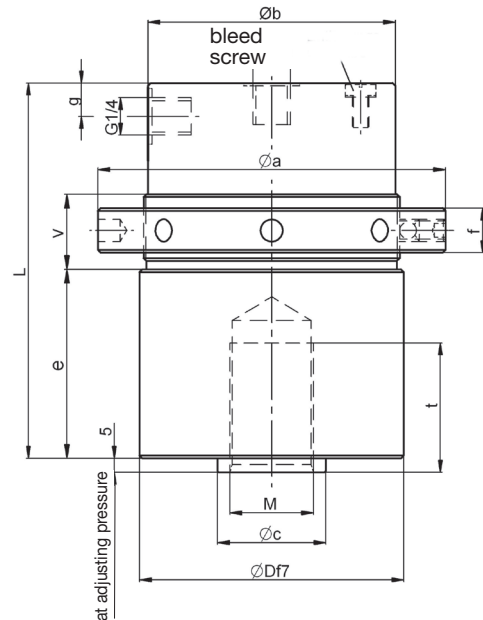
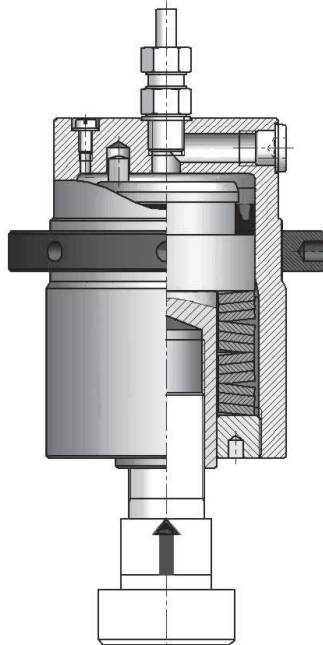

Dimensions [mm]: length dimensions according to DIN ISO 2768 mH

| ZSF Size | Ø D f7 | "Version-2" Ø D f7 | Ø a | Ø b | Ø c | e   | f  | g    | L   | M*         | t  | v  | adjustment thread - ring nut |
|----------|--------|--------------------|-----|-----|-----|-----|----|------|-----|------------|----|----|------------------------------|
| 1.600    | 60     | 55                 | 85  | 55  | 20  | 40  | 14 | 12   | 101 | M 14 x 1,5 | 24 | 22 | M 58 x 1,5                   |
| 2.500    | 70     | 65                 | 95  | 65  | 25  | 46  | 14 | 13   | 111 | M 18 x 1,5 | 30 | 23 | M 68 x 1,5                   |
| 4.000    | 80     | 75                 | 110 | 75  | 30  | 56  | 16 | 12   | 125 | M 22 x 1,5 | 36 | 24 | M 78 x 1,5                   |
| 6.300    | 95     | 85                 | 125 | 89  | 40  | 67  | 16 | 12   | 135 | M 30 x 1,5 | 48 | 28 | M 92 x 1,5                   |
| 10.000   | 105    | 95                 | 140 | 100 | 40  | 78  | 16 | 18,5 | 150 | M 30 x 1,5 | 50 | 35 | M 102 x 1,5                  |
| 16.000   | 142    | 130                | 180 | 137 | 50  | 75  | 32 | 22   | 170 | M 38 x 1,5 | 50 | 50 | M 140 x 2                    |
| 20.000   | 150    | -                  | 190 | 143 | 57  | 92  | 40 | 22   | 200 | M 45 x 1,5 | 60 | 58 | M 148 x 3                    |
| 25.000   | 170    | -                  | 220 | 163 | 70  | 100 | 40 | 22   | 230 | M 45 x 1,5 | 60 | 58 | M 168 x 3                    |
| 35.000   | 200    | -                  | 250 | 192 | 80  | 100 | 45 | 47   | 240 | M 52 x 1,5 | 70 | 65 | M 198 x 3                    |

**Note Version-2:** Sizes 1.600 to 10.000 are available alternatively with smaller external diameter "D" cylinder housing according to column "-2". Other thread sizes or through holes available on request.

\*Alternative threaded version available on request

Ordering example: ZSF 25.000 / ZSF 6.300 - 2

## Spring Clamping Cylinder I Series ZDF-o

- /// mechanical clamping – hydraulic releasing
- /// high operational safety // leak-proof and robust
- /// temperature range: -30°C up to +100°C // mounting position discretionary

### Technical data:

| ZDF-o size | nominal clamping force [kN] | adjusting pressure [bar] | release pressure at 0,5 mm stroke [bar] | release pressure at 1,0 mm stroke [bar] | stroke volume at 1 mm stroke [cm <sup>3</sup> ] | mass approx. [kg] |
|------------|-----------------------------|--------------------------|---|---|---|-------------------|
| 2.500      | 25                          | 130                      | 160                                     | 195                                     | 2   | 3                 |
| 4.000      | 40                          | 200                      | 240                                     | 280                                     | 3   | 4,4               |
| 6.300      | 63                          | 180                      | 200                                     | 225                                     | 4   | 6,0               |
| 10.000     | 100                         | 240                      | 270                                     | 300                                     | 5   | 12                |
| 16.000     | 160                         | 205                      | 235                                     | 265                                     | 8   | 23                |
| 25.000     | 250                         | 200                      | 220                                     | 245                                     | 14  | 35                |

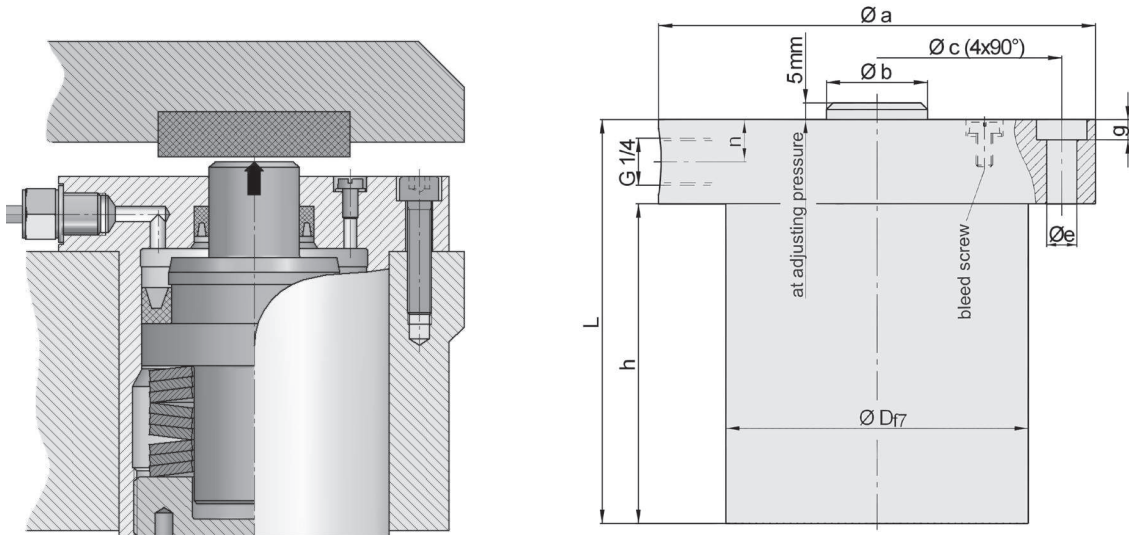

**material:**  
heat treated steel, burnished or nitro carburized

**Dimensions [mm]:** length dimensions according to DIN ISO 2768 mH

| ZDF-o  | Ø D | Ø a | Ø b | Ø c | Ø e | g  | h   | L   | n    |
|--------|-----|-----|-----|-----|-----|----|-----|-----|------|
| 2.500  | 70  | 95  | 20  | 82  | 6,5 | 7  | 75  | 100 | 12,5 |
| 4.000  | 80  | 120 | 30  | 100 | 9   | 9  | 85  | 110 | 12,5 |
| 6.300  | 90  | 130 | 30  | 110 | 9   | 9  | 95  | 120 | 12,5 |
| 10.000 | 115 | 160 | 30  | 140 | 11  | 10 | 120 | 145 | 12,5 |
| 16.000 | 150 | 198 | 40  | 175 | 13  | 12 | 130 | 160 | 15   |
| 25.000 | 180 | 230 | 50  | 205 | 13  | 12 | 140 | 170 | 15   |

**Ordering example: ZDF-o 4.000**

## Spring Clamping Cylinder I Series ZDF-u

- /// mechanical clamping – hydraulic release
- /// high operational safety // leak-proof and robust
- /// temperature range: -30°C to +100°C // mounting position discretionary

### Technical data:

| ZDF-u Size | nominal clamping force [kN] | adjusting pressure [bar] | max release stroke [mm] | release pressure at 0,5 mm stroke [bar] | release pressure at 1,0 mm stroke [bar] | release pressure at max stroke [bar] | stroke volume at 1 mm stroke [cm <sup>3</sup> ] | mass approx. [kg] |
|------------|-----------------------------|--------------------------|-------------------------|---|---|--------------------------------------|---|-------------------|
| 2.500      | 25                          | 160                      | 1,2                     | 205                                     | 250                                     | 270                                  | 2,0   | 3,8               |
| 4.000      | 40                          | 200                      | 1,5                     | 240                                     | 280                                     | 320                                  | 2,3   | 5,7               |
| 6.300      | 63                          | 180                      | 1,0                     | 205                                     | 230                                     | 230                                  | 4   | 7,8               |
| 10.000     | 100                         | 210                      | 1,0                     | 240                                     | 270                                     | 270                                  | 6   | 14                |
| 16.000     | 160                         | 205                      | 1,5                     | 250                                     | 290                                     | 330                                  | 9   | 25                |
| 25.000     | 250                         | 200                      | 1,5                     | 230                                     | 260                                     | 300                                  | 13  | 34                |

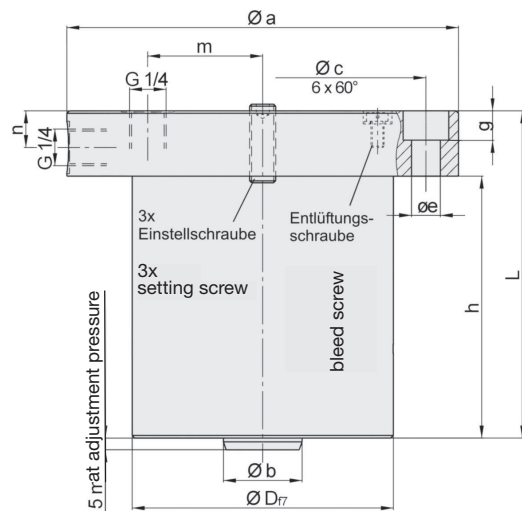
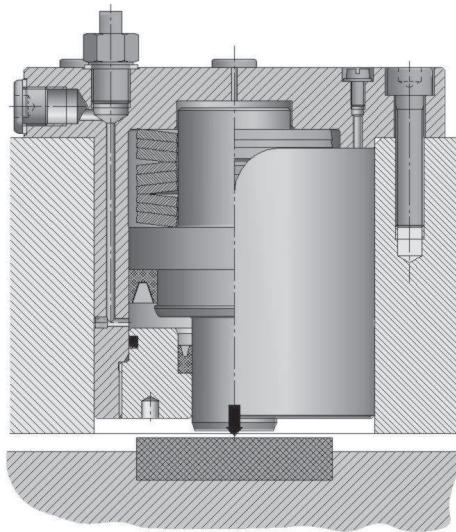

**material:**  
heat treated steel, burnished or nitro carburized

### Dimensions [mm]: length dimensions according to DIN ISO 2768 mH

| ZDF-u  | Ø D | Ø a | Ø b | Ø c | Ø e  | g  | h   | L   | m  | n  |
|--------|-----|-----|-----|-----|------|----|-----|-----|----|----|
| 2.500  | 75  | 105 | 20  | 90  | 6,5  | 7  | 85  | 110 | 30 | 14 |
| 4.000  | 90  | 138 | 30  | 115 | 11   | 10 | 90  | 115 | 37 | 14 |
| 6.300  | 100 | 150 | 30  | 125 | 11   | 10 | 100 | 125 | 44 | 14 |
| 10.000 | 120 | 170 | 30  | 145 | 12,5 | 12 | 125 | 150 | 51 | 14 |
| 16.000 | 150 | 210 | 40  | 185 | 12,5 | 12 | 140 | 170 | 65 | 15 |
| 25.000 | 180 | 230 | 50  | 205 | 12,5 | 12 | 150 | 180 | 80 | 15 |

Ordering example: ZDF-u 6.300

# Operation Manual - Slide Clamping I ZSF

1.

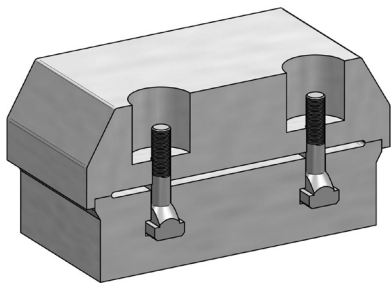

T-bolt screw or tension bolt installation (consider twist lock)

2.

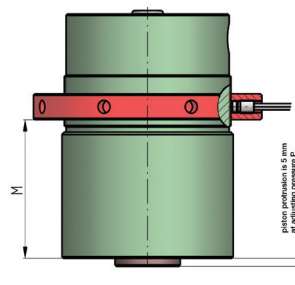

adjust ring nut to mounting position (M) and lock

3.

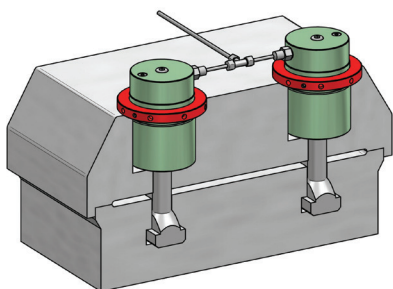

installation of cylinder, hydraulics -> bleeding of cylinder

4.

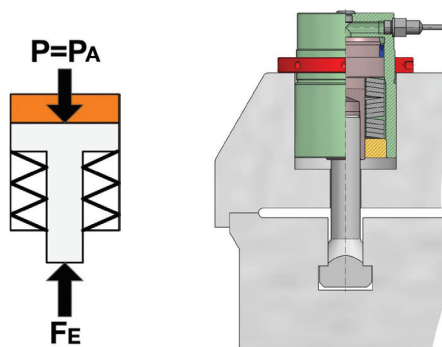

load cylinder with adjusting pressure  $P_A$  - disk spring package is compressed - T-bolt screw is released by stroke of pressure piston

5.

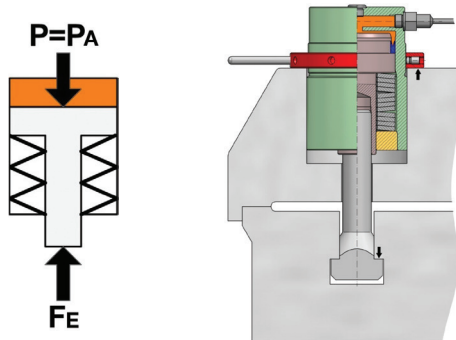

turn ring nut until ring nut and tensioning bolt are at mechanical stop - lock ring nut with screw

6.

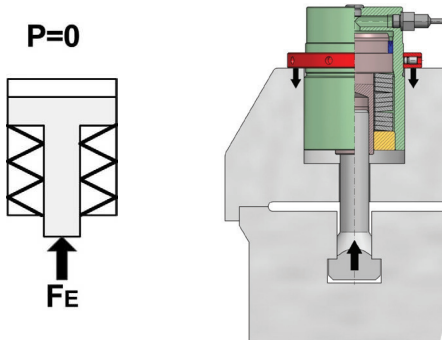

release hydraulic pressure -  $P = 0$  bar - clamping force of disk spring package =  $F_N$

7.

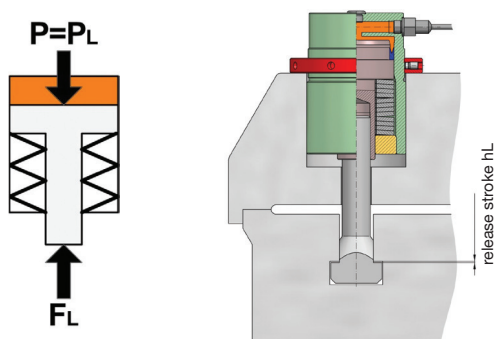

load with release pressure  $P_L$ , disk spring package is compressed further

8.

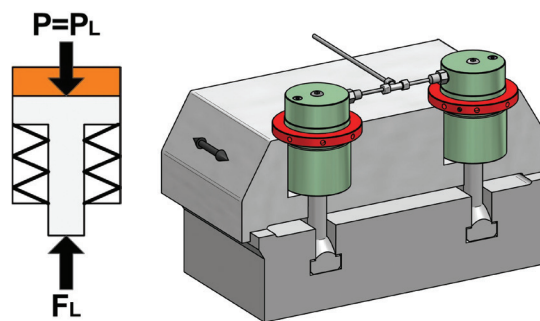

T-bolt screw and tensioning bolt are in release position. Slide can be moved axially



Distributore per l'Italia:  
Homberger S.p.A.  
Via dei Lavoratori 8/10  
20090 Buccinasco (MI)  
e-mail: [commerciale@homberger.com](mailto:commerciale@homberger.com)