



# IB series P2 type

Planetary gear drive  
for servo motor



# IB Series P2 Type

## Table of Contents

• Structure	... 2
• Features	... 3
• Nomenclature, Standard specification	... 4
• Selection Table 1 (Frame size combination table for each motor rated speed)	... 5
• No load running torque	... 5
• Selection Table 2 (Frame size combination table for each servo motor manufactures)	
1. Fanuc Corporation	... 6
2. Mitsubishi Electric Corporation	... 8
3. Yaskawa Electric Corporation	... 10
4. Sanyo Denki Co.,Ltd.	... 11
5. Panasonic Corporation	... 12
• Selection Table 3 (Rating table) (Allowable radial & axial load on the output flange)	... 14
• Selection procedure	... 18
• Dimension drawings	... 20
• Nominal life calculation of main bearing	... 24
• Mechanical accuracy of output part of the reducer	... 26
• Tightening torque and allowable transmitted torque for output flange bolts	... 26
• Solid shaft design (Option)	... 26
• Motor installation procedure	... 27
• Moment of inertia, $GD^2$ (at motor shaft)	... 28
• Formula for calculation of Moment of inertia, Load torque and Acceleration torque	... 29
• Formula for calculation of Moment of inertia, $GD^2$	... 30
• Motor accuracy	... 31
• Warranty and safety precautions	... 32

## Structure

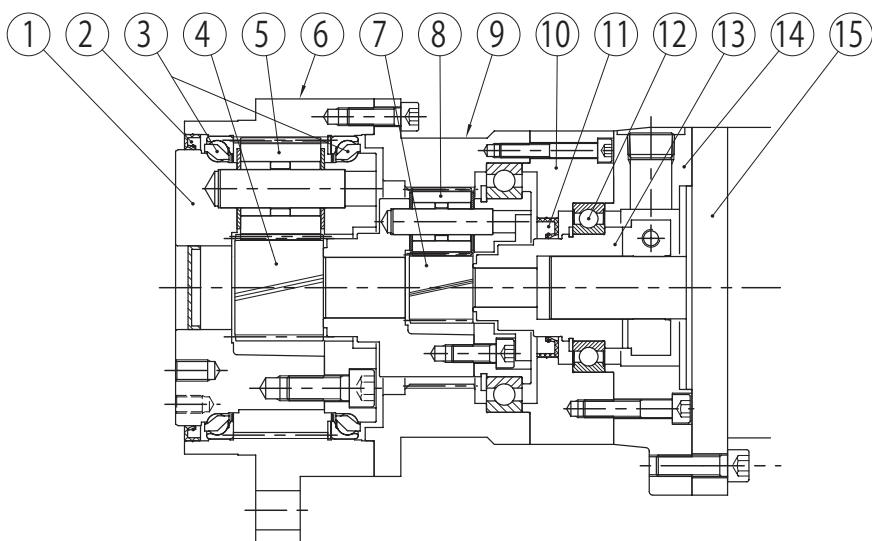
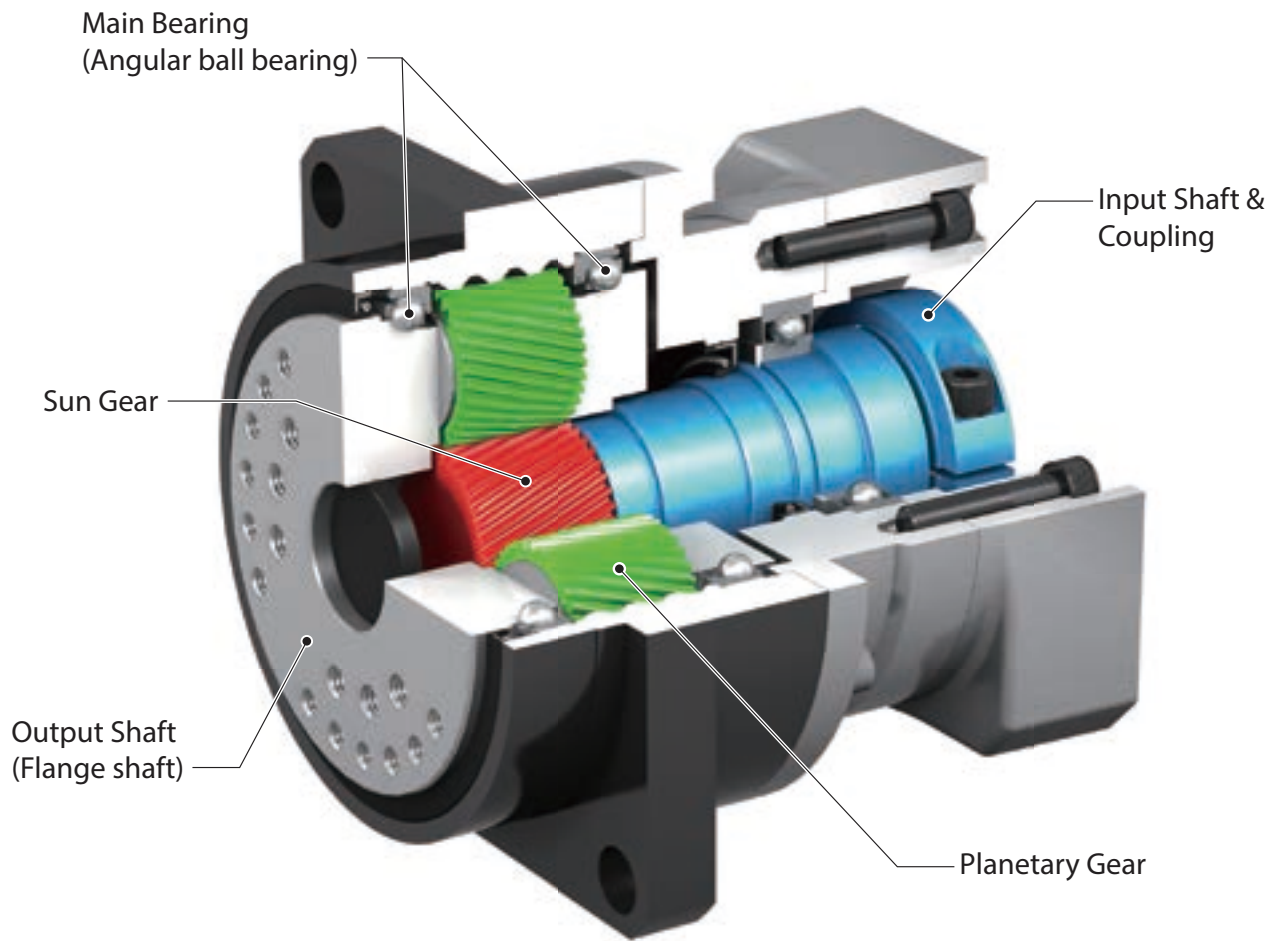

Number	Part Name
1	Output Shaft
2	Oil seal
3	Main Bearing
4	Sun Gear of Output
5	Planetary Gear of Output
6	Casing with Internal Gear
7	Sun Gear of Input
8	Planetary Gear of Input
9	Internal Gear of Input
10	Adapter (Casing)
11	Oil seal
12	Input Shaft Bearing
13	Coupling
14	Adapter Plate
15	Motor (Provided by Customers)

Structure (2-stage unit)

## Specifications

- Backlash Initial backlash setting is 3minutes
- Rated torque 350 - 1500N·m
- Allowable peak torque 650 - 3000N·m
- Allowable maximum input speed 6000r/min  
(Frame size P240 Reduction ratio 16 - 100)
- Reduction system Planetary gear mechanism

## Features

- No.1 Compactness in the industry  
Large diameter precision angular bearing, supporting output shaft, allows large radial load with compact casing.
- Responsiveness to Newest Servo Motors for Simpler Applications!
- Low noise using helical gear.

Motion Control Drive of Sumitomo Drive Technologies are available for various areas requiring precision control.

### Application Examples

Recommended models	<b>F</b>	CYCLO DRIVE F Series
	<b>IB</b>	IB Series
	<b>SV</b>	CYCLO DRIVE for servo motors

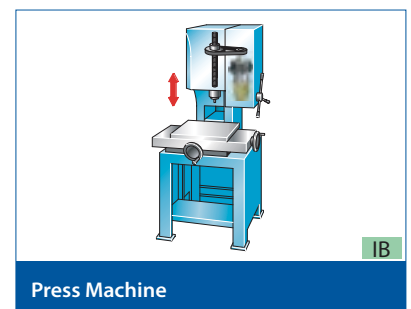
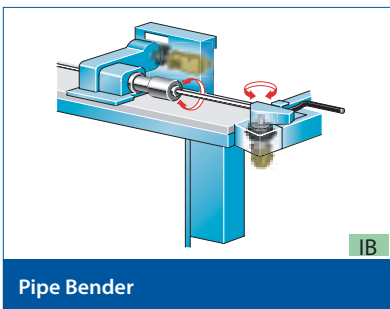
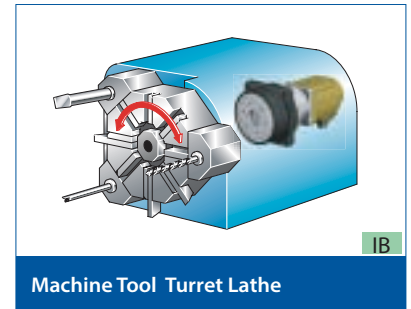

# Nomenclature, Standard Specification

## Nomenclature

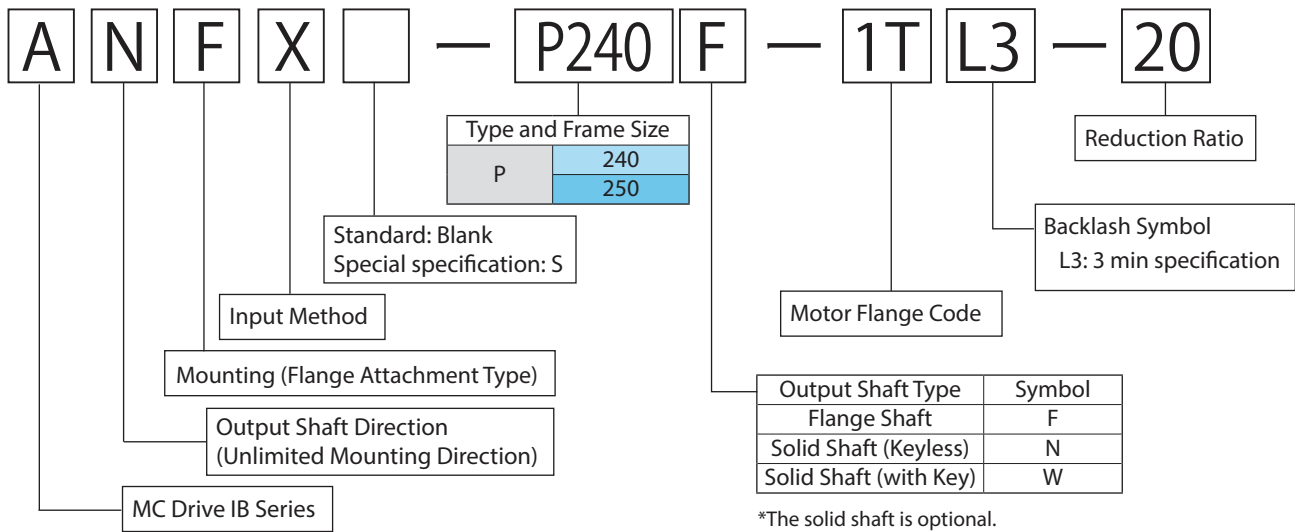

Ratio (= exact ratio)	1-stage				2-stage								
		4	5	7	10	16	20	25	28	35	40	50	70

## Standard Specification

Backlash	Initial backlash setting is 3-minutes
Efficiency (Note 1)	90% or more at rated output torque (with reduction ratio 4, 5, 7, 10)
Noise Level (Note 2)	70dB(A) 0.5m
Lubrication system	Grease lubrication The units are filled with grease at the time of shipping. It is ready for immediate use.
Reduction system	Planetary gear mechanism Single stage type (Reduction Ratio: 4, 5, 7, 10) Double stage type (Reduction Ratio: 16, 20, 25, 28, 35, 40, 50, 70, 100)
Output shaft rotation direction	Same direction as the rotation direction of input gear.
Material	Case with internal gear and gear : Chrome-Molybdenum Steel Output and input shaft : S45C
Mounting location	Indoor (without dust and water)
Ambient temperature	0 ~ 40°C Consult us when the operation condition exceeds the above and when special grease is necessary such as food manufacturing machine.
Ambient humidity	85% or less. There should be no condensation.
Altitude	1000m or below
Ambient atmosphere	There should be no corrosive gases, explosive gases, vapor, or dust.
Mounting angle	All angles possible (no limitation)
Paint	Black oxide coating for housing with internal gear Output shaft comes with rustproof treatment at the time of shipping.
Actual reduction ratio	Please refer ratio table above.
Surface temperature of the reducer	80°C or below. Consult us for continuous operation.

Note) 1. The efficiency depends on input speed, load torque, grease temperature, reduction ratio, etc.  
2. This is a reference value. It depends on the type and mounting condition.

# Selection Table 1 (Frame Size Combination Table for Each Motor Rated Speed)

Rated Motor Speed 1000 [r/min]

Servo Motor Capacity (kW)	Reduction Ratio												
	4	5	7	10	16	20	25	28	35	40	50	70	100
0.5	■	■	■	■	■	■	■	■	■	■	■	■	●
1.0	■	■	■	■	■	■	■	■	■	■	■	■	●
1.2	■	■	■	■	■	■	■	■	■	■	■	■	●
1.5	■	■	■	■	■	■	■	■	■	■	■	■	●
2.0	■	■	■	■	■	■	■	■	■	■	■	■	●
2.5	■	■	■	■	■	■	■	■	■	■	■	■	●
3.0	■	■	■	■	■	■	■	■	■	■	■	■	●
3.5	■	■	■	■	■	■	■	■	■	■	■	■	●
4.0	■	■	■	■	■	■	■	■	■	■	■	■	●
4.5	■	■	■	■	■	■	■	■	■	■	■	■	●
5.0	■	■	■	■	■	■	■	■	■	■	■	■	●
5.5	■	■	■	■	■	■	■	■	■	■	■	■	●
6.0	■	■	■	■	■	■	■	■	■	■	■	■	●
7.0	■	■	■	■	■	■	■	■	■	■	■	■	●
8.0	■	■	■	■	■	■	■	■	■	■	■	■	●
9.0	■	■	■	■	■	■	■	■	■	■	■	■	●
11	■	■	■	■	■	■	■	■	■	■	■	■	●
15	■	■	■	■	■	■	■	■	■	■	■	■	●
20	■	■	■	■	■	■	■	■	■	■	■	■	●
22	■	■	■	■	■	■	■	■	■	■	■	■	●
25	■	■	■	■	■	■	■	■	■	■	■	■	●
30	■	■	■	■	■	■	■	■	■	■	■	■	●
37	■	■	■	■	■	■	■	■	■	■	■	■	●

Rated Motor Speed 1500 [r/min]

Servo Motor Capacity (kW)	Reduction Ratio												
	4	5	7	10	16	20	25	28	35	40	50	70	100
0.5	■	■	■	■	■	■	■	■	■	■	■	■	●
1.0	■	■	■	■	■	■	■	■	■	■	■	■	●
1.2	■	■	■	■	■	■	■	■	■	■	■	■	●
1.5	■	■	■	■	■	■	■	■	■	■	■	■	●
2.0	■	■	■	■	■	■	■	■	■	■	■	■	●
2.5	■	■	■	■	■	■	■	■	■	■	■	■	●
3.0	■	■	■	■	■	■	■	■	■	■	■	■	●
3.5	■	■	■	■	■	■	■	■	■	■	■	■	●
4.0	■	■	■	■	■	■	■	■	■	■	■	■	●
4.5	■	■	■	■	■	■	■	■	■	■	■	■	●
5.0	■	■	■	■	■	■	■	■	■	■	■	■	●
5.5	■	■	■	■	■	■	■	■	■	■	■	■	●
6.0	■	■	■	■	■	■	■	■	■	■	■	■	●
7.0	■	■	■	■	■	■	■	■	■	■	■	■	●
8.0	■	■	■	■	■	■	■	■	■	■	■	■	●
9.0	■	■	■	■	■	■	■	■	■	■	■	■	●
11	■	■	■	■	■	■	■	■	■	■	■	■	●
15	■	■	■	■	■	■	■	■	■	■	■	■	●
20	■	■	■	■	■	■	■	■	■	■	■	■	●
22	■	■	■	■	■	■	■	■	■	■	■	■	●
25	■	■	■	■	■	■	■	■	■	■	■	■	●
30	■	■	■	■	■	■	■	■	■	■	■	■	●
37	■	■	■	■	■	■	■	■	■	■	■	■	●

Rated Motor Speed 2000 [r/min]

Servo Motor Capacity (kW)	Reduction Ratio												
	4	5	7	10	16	20	25	28	35	40	50	70	100
0.5	■	■	■	■	■	■	■	■	■	■	■	■	●
1.0	■	■	■	■	■	■	■	■	■	■	■	■	●
1.2	■	■	■	■	■	■	■	■	■	■	■	■	●
1.5	■	■	■	■	■	■	■	■	■	■	■	■	●
2.0	■	■	■	■	■	■	■	■	■	■	■	■	●
2.5	■	■	■	■	■	■	■	■	■	■	■	■	●
3.0	■	■	■	■	■	■	■	■	■	■	■	■	●
3.5	■	■	■	■	■	■	■	■	■	■	■	■	●
4.0	■	■	■	■	■	■	■	■	■	■	■	■	●
4.5	■	■	■	■	■	■	■	■	■	■	■	■	●
5.0	■	■	■	■	■	■	■	■	■	■	■	■	●
5.5	■	■	■	■	■	■	■	■	■	■	■	■	●
6.0	■	■	■	■	■	■	■	■	■	■	■	■	●
7.0	■	■	■	■	■	■	■	■	■	■	■	■	●
8.0	■	■	■	■	■	■	■	■	■	■	■	■	●
9.0	■	■	■	■	■	■	■	■	■	■	■	■	●
11	■	■	■	■	■	■	■	■	■	■	■	■	●
15	■	■	■	■	■	■	■	■	■	■	■	■	●
20	■	■	■	■	■	■	■	■	■	■	■	■	●
22	■	■	■	■	■	■	■	■	■	■	■	■	●
25	■	■	■	■	■	■	■	■	■	■	■	■	●
30	■	■	■	■	■	■	■	■	■	■	■	■	●
37	■	■	■	■	■	■	■	■	■	■	■	■	●

Rated Motor Speed 3000 [r/min]

Servo Motor Capacity (kW)	Reduction Ratio												
	4	5	7	10	16	20	25	28	35	40	50	70	100
0.5	■	■	■	■	■	■	■	■	■	■	■	■	●
1.0	■	■	■	■	■	■	■	■	■	■	■	■	●
1.2	■	■	■	■	■	■	■	■	■	■	■	■	●
1.5	■	■	■	■	■	■	■	■	■	■	■	■	●
2.0	■	■	■	■	■	■	■	■	■	■	■	■	●
2.5	■	■	■	■	■	■	■	■	■	■	■	■	●
3.0	■	■	■	■	■	■	■	■	■	■	■	■	●
3.5	■	■	■	■	■	■	■	■	■	■	■	■	●
4.0	■	■	■	■	■	■	■	■	■	■	■	■	●
4.5	■	■	■	■	■	■	■	■	■	■	■	■	●
5.0	■	■	■	■	■	■	■	■	■	■	■	■	●
5.5	■	■	■	■	■	■	■	■	■	■	■	■	●
6.0	■	■	■	■	■	■	■	■	■	■	■	■	●
7.0	■	■	■	■	■	■	■	■	■	■	■	■	●
8.0	■	■	■	■	■	■	■	■	■	■	■	■	●
9.0	■	■	■	■	■	■	■	■	■	■	■	■	●
11	■	■	■	■	■	■	■	■	■	■	■	■	●
15	■	■	■	■	■	■	■	■	■	■	■	■	●
20	■	■	■	■	■	■	■	■	■	■	■	■	●
22	■	■	■	■	■	■	■	■	■	■	■	■	●
25	■	■	■	■	■	■	■	■	■	■	■	■	●
30	■	■	■	■	■	■	■	■	■	■	■	■	●
37	■	■	■	■	■	■	■	■	■	■	■	■	●

- Note) 1. Smaller frame size (P1 series) is recommended when using combination with ■, please refer the catalog for IB series P1 type (catalog no. Z2004E).  
 2. Refer to Selection Table 3 (on pages 14, 15) for rated torque, allowable acceleration or deceleration peak torque, allowable maximum momentary torque, allowable maximum input speed, and allowable mean input speed for each frame size.  
 3. Refer to Selection Table 3 (on pages 14, 15) for %ED and allowable continuous operation period of each speed.  
 4. Refer to Selection Table 3 (on pages 14, 15) for allowable acceleration or deceleration peak torque for combinations marked ●.  
 5. Note the no load running torque (below table) when using combination with □. Please choose smaller units (P1 type) or larger motor when no load running torque is too large for your application.

### No Load Running Torque (N·m)

Frame Size	Reduction Ratio												
	4	5	7	10	16	20	25	28	35	40	50	70	100
P240	6.2	5.4	4.8	4.3	3.3	2.9	2.5	2.5	2.2	2.1	1.9	1.7	1.5
P250	11.0	9.7	8.4	7.5	5.8	5.0	4.4	4.2	3.7	3.6	3.2	2.7	2.4

- Note) 1. Torque necessary at the input side to rotate the reducer at no load condition.  
 2. This is the representative value when the ambient temperature is 20°C.

# Selection Table 2 (Frame Size Combination Table for Each Servo Motor Manufactures)

## 1. Fanuc Corporation

### βis Series (Rated speed: 2000 ~ 1500r/min)

\* ● is available to be driven by rated torque.

Servo Motor Capacity (W)	Nomenclature of Servo Motor		Reduction Ratio													Motor Flange Code	
	Type	Rated Speed (r/min)	4	5	7	10	16	20	25	28	35	40	50	70	100		
1400	βiS12/2000	2000						P240	P240	P240	P240	P240	P240	● P240 P250	P250	DA	
1800	βiS12/3000 (HV)	2000				P240	P240	P240	P240	P240	P240	P240	● P240 P250	● P240 P250	● P250	DA	
2500	βiS22/2000 (HV)	2000			P240	P240	P240	P240	● P240 P250	● P240 P250	● P240 P250	● P240 P250	● P240 P250	P250	● P250	0X	
3000	βiS22/3000 (HV)	2000			P240	P240	P240	P240	● P240 P250	● P240 P250	● P240 P250	● P240 P250	P250	P250	P250	-	0X
3000	βiS30/2000 (HV)	2000			P240	P240	P240	● P240 P250	● P240 P250	● P240 P250	● P240 P250	● P240 P250	P250	P250	● P250	-	0X
3000	βiS40/2000 (HV)	1500			P240	● P240 P250	● P240 P250	● P240 P250	● P240 P250	● P240 P250	● P240 P250	P250	P250	● P250	● P250	-	0X

### αis Series (Rated speed: 6000 ~ 2000r/min)

Servo Motor Capacity (W)	Nomenclature of Servo Motor		Reduction Ratio													Motor Flange Code	
	Type	Rated Speed (r/min)	4	5	7	10	16	20	25	28	35	40	50	70	100		
2500	αiS12/4000HV	3000				P240	P240	P240	● P240 P250	● P240 P250	● P240 P250	● P240 P250	● P240 P250	● P240 P250	● P240 P250	● P250	DA
2700	αiS12/4000	3000				P240	P240	P240	● P240 P250	● P240 P250	● P240 P250	● P240 P250	● P240 P250	● P240 P250	● P240 P250	● P250	DA
4500	αiS22/4000	3000			P240	● P240 P250	● P240 P250	● P240 P250	● P240 P250	● P240 P250	● P240 P250	P250	● P250	● P250	● P250	-	0X
4500	αiS22/4000HV	3000			P240	P240	● P240 P250	● P240 P250	● P240 P250	● P240 P250	● P240 P250	P250	P250	● P250	-	0X	
4500	αiS22/6000 (HV)	6000	-	-	-	-	P240	P240	● P240 P250	● P240 P250	● P240 P250	● P240 P250	● P240 P250	-	-	-	0X
5000	αiS50/3000 (HV)	2000	P240	P240	P240	● P240 P250	● P240 P250	● P240 P250	● P240 P250	● P250	● P250	● P250	● P250	● P250	● P250	-	0X
5500	αiS30/4000 (HV)	3000	P240	P240	P240	● P240 P250	● P240 P250	● P240 P250	● P240 P250	● P240 P250	● P240 P250	● P250	● P250	● P250	● P250	-	0X
5500	αiS40/4000 (HV)	3000	P240	P240	P240	● P240 P250	● P240 P250	● P240 P250	● P240 P250	● P240 P250	● P240 P250	● P250	● P250	● P250	● P250	-	0X
14000	αiS50/3000 (HV) with fan	3000	P240	● P240 P250	● P240 P250	P250	P250	● P250	● P250	● P250	● P250	-	-	-	-	-	0X

### βiSc Series (Rated speed: 2000r/min)

Servo Motor Capacity (W)	Nomenclature of Servo Motor		Reduction Ratio													Motor Flange Code
	Type	Rated Speed (r/min)	4	5	7	10	16	20	25	28	35	40	50	70	100	
1400	βiSc12/2000	2000						P240	P240	P240	P240	P240	P240	● P240 P250	P250	DA

### βiF Series (Rated speed: 2000 ~ 1500r/min)

Servo Motor Capacity (W)	Nomenclature of Servo Motor		Reduction Ratio													Motor Flange Code
	Type	Rated Speed (r/min)	4	5	7	10	16	20	25	28	35	40	50	70	100	
1400	βiF12/2000	2000						P240	P240	P240	P240	P240	● P240 P250	● P240 P250	● P250	0X
2500	βiF22/2000	2000			P240	P240	P240	P240	● P240 P250	● P240 P250	● P240 P250	● P240 P250	● P240 P250	P250	● P250	0X
3000	βiF30/2000	1500			P240	● P240 P250	● P240 P250	● P240 P250	● P240 P250	● P240 P250	● P250	● P250	● P250	● P250	-	0X

Refer Note 3 "- " N/A

- Note) 1. Refer to Selection Table 3 (on pages 14-17) for rated torque, allowable maximum input speed, allowable peak torque, and allowable radial and axial load for each frame size.  
 2. Refer to Selection Table 3 (on pages 14-15) for allowable acceleration or deceleration peak torque for combinations marked ●.  
 3. Smaller frame size (P1 series) is recommended when using combination with , please refer the catalog for IB series P1 type (catalog no. Z2004E).

# Selection Table 2 (Frame Size Combination Table for Each Servo Motor Manufactures)

## aiF Series (Rated speed: 3000 ~ 2000r/min)

Servo Motor Capacity (W)	Nomenclature of Servo Motor		Reduction Ratio													Motor Flange Code
	Type	Rated Speed [r/min]	4	5	7	10	16	20	25	28	35	40	50	70	100	
3000	aiF12/3000 (HV)	3000				P240	P240	P240	P240	P240	● P240 P250	● P240 P250	● P240 P250	P250	● P250	OX
4000	aiF22/3000 (HV)	3000			P240	P240	P240	● P240 P250	● P240 P250	● P240 P250	● P240 P250	● P240 P250	P250	● P250	-	OX
6000	aiF40/3000	2000	P240	P240	P240	● P240 P250	● P240 P250	● P240 P250	P250	P250	● P250	● P250	● P250	-	-	OX
7000	aiF30/3000	3000	P240	P240	P240	● P240 P250	● P240 P250	● P240 P250	● P240 P250	P250	P250	P250	● P250	● P250	-	OX
9000	aiF40/3000 with fan	2000	P240	P240	P240	P250	P250	P250	P250	P250	● P250	● P250	-	-	-	OX

Refer Note 3 "-" N/A

- Note) 1. Refer to Selection Table 3 (on pages 14-17) for rated torque, allowable maximum input speed, allowable peak torque, and allowable radial and axial load for each frame size.  
 2. Refer to Selection Table 3 (on pages 14-15) for allowable acceleration or deceleration peak torque for combinations marked ●.  
 3. Smaller frame size (P1 series) is recommended when using combination with , please refer the catalog for IB series P1 type (catalog no. Z2004E).

# Selection Table 2 (Frame Size Combination Table for Each Servo Motor Manufactures)

## 2. Mitsubishi Electric Corporation

### MELSERVO-J4

#### HG-JR Series (Rated speed: 1500r/min, 200V&400V class)

\* ● is available to be driven by rated torque.

Servo Motor Capacity (W)	Nomenclature of Servo Motor		Reduction Ratio													Motor Flange Code
	Type	Rated Speed (r/min)	4	5	7	10	16	20	25	28	35	40	50	70	100	
11000	HG-JR11K1M (B) HG-JR11K1M4 (B)	1500	P240	● P240 P250	● P240 P250	P250	P250	● P250	● P250	-	-	-	-	-	-	DL
15000	HG-JR15K1M (B) HG-JR15K1M4 (B)	1500	● P240 P250	● P240 P250	P250	● P250	● P250	-	-	-	-	-	-	-	-	DL

#### MELSERVO-J4 HG-JR Series (Rated speed: 3000r/min, 200V&400V class)

Servo Motor Capacity (W)	Nomenclature of Servo Motor		Reduction Ratio													Motor Flange Code
	Type	Rated Speed (r/min)	4	5	7	10	16	20	25	28	35	40	50	70	100	
3300	HG-JR353 (B) HG-JR3534 (B)	3000				P240	P240	P240	P240	P240	● P240 P250	● P240 P250	● P240 P250	P250	● P250	1T
5000	HG-JR503 (B) HG-JR5034 (B)	3000			P240	P240	P240	P240	● P240 P250	● P240 P250	● P240 P250	P250	P250	P250	-	1T
7000	HG-JR703 (B) HG-JR7034 (B)	3000	P240	P240	P240	P240	P240	● P240 P250	● P240 P250	P250	P250	P250	P250	● P250	-	0X
9000	HG-JR903 (B) HG-JR9034 (B)	3000	P240	P240	P240	● P240 P250	● P240 P250	● P240 P250	P250	P250	P250	P250	● P250	-	-	0X

#### MELSERVO-J4 HG-RR Series (Rated speed: 3000r/min)

Servo Motor Capacity (W)	Nomenclature of Servo Motor		Reduction Ratio													Motor Flange Code
	Type	Rated Speed (r/min)	4	5	7	10	16	20	25	28	35	40	50	70	100	
1000	HG-RR103 (B)	3000							P240	P240	P240	P240	P240	P240	P240	7Y
1500	HG-RR153 (B)	3000							P240	P240	P240	P240	P240	P240	P250	7Y
2000	HG-RR203 (B)	3000						P240	P240	P240	P240	P240	P240	● P240 P250	P250	7Y
3500	HG-RR353 (B)	3000				P240	P240	P240	P240	P240	P240	● P240 P250	● P240 P250	P250	● P250	1T
5000	HG-RR503 (B)	3000			P240	P240	P240	P240	P240	● P240 P250	● P240 P250	P250	P250	P250	-	1T

#### MELSERVO-J4 HG-SR Series (Rated speed: 1000r/min)

Servo Motor Capacity (W)	Nomenclature of Servo Motor		Reduction Ratio													Motor Flange Code
	Type	Rated Speed (r/min)	4	5	7	10	16	20	25	28	35	40	50	70	100	
500	HG-SR51 (B)	1000							P240	P240	P240	P240	P240	P240	P250	DA
850	HG-SR81 (B)	1000					P240	P240	P240	P240	P240	P240	● P240 P250	● P240 P250	P250	DA
1200	HG-SR121 (B)	1000				P240	P240	P240	P240	P240	● P240 P250	● P240 P250	● P240 P250	P250	● P250	0X
2000	HG-SR201 (B)	1000			P240	P240	P240	● P240 P250	● P240 P250	● P240 P250	P250	P250	P250	● P250	-	0X
3000	HG-SR301 (B)	1000	P240	P240	P240	● P240 P250	● P240 P250	● P240 P250	P250	P250	P250	P250	● P250	-	-	0X
4200	HG-SR421 (B)	1000	P240	P240	P240	P250	P250	P250	P250	P250	● P250	● P250	-	-	-	0X

Refer Note 3 "- " N/A

- Note) 1. Refer to Selection Table 3 (on pages 14-17) for rated torque, allowable maximum input speed, allowable peak torque, and allowable radial and axial load for each frame size.  
 2. Refer to Selection Table 3 (on pages 14-15) for allowable acceleration or deceleration peak torque for combinations marked ●.  
 3. Smaller frame size (P1 series) is recommended when using combination with , please refer the catalog for IB series P1 type (catalog no. Z2004E).  
 4. Confirm no-load running torque when models   is selected. If it has large no-load running torque, consider to use IB-P1 type.

# Selection Table 2 (Frame Size Combination Table for Each Servo Motor Manufactures)

## MELSERVO-J4 HG-SR Series (Rated speed: 2000r/min, 200V&400V class)

Servo Motor Capacity (W)	Nomenclature of Servo Motor		Reduction Ratio													Motor Flange Code
	Type	Rated Speed (r/min)	4	5	7	10	16	20	25	28	35	40	50	70	100	
500	HG-SR52 (B) HG-SR524 (B)	2000										P240	P240	P240	P240	DA
1000	HG-SR102 (B) HG-SR1024 (B)	2000							P240	P240	P240	P240	P240	P240	P250	DA
1500	HG-SR152 (B) HG-SR1524 (B)	2000						P240	P240	P240	P240	P240	P240	● P240 P250	P250	DA
2000	HG-SR202 (B) HG-SR2024 (B)	2000				P240	P240	P240	P240	P240	P240	● P240 P250	● P240 P250	P250	● P250	OX
3500	HG-SR352 (B) HG-SR3524 (B)	2000			P240	P240	P240	P240	● P240 P250	● P240 P250	● P240 P250	P250	P250	P250	-	OX
5000	HG-SR502 (B) HG-SR5024 (B)	2000	P240	P240	P240	P240	● P240 P250	● P240 P250	● P240 P250	P250	P250	P250	P250	● P250	-	OX
7000	HG-SR702 (B) HG-SR7024 (B)	2000	P240	P240	P240	● P240 P250	● P240 P250	P250	P250	P250	P250	● P250	● P250	-	-	OX

## MELSERVO-J4 HG-UR Series (Rated speed: 2000r/min)

Servo Motor Capacity (W)	Nomenclature of Servo Motor		Reduction Ratio													Motor Flange Code
	Type	Rated Speed (r/min)	4	5	7	10	16	20	25	28	35	40	50	70	100	
1500	HG-UR152 (B)	2000						P240	P240	P240	P240	P240	P240	● P240 P250	P250	DC
2000	HG-UR202 (B)	2000				P240	P240	P240	P240	P240	P240	● P240 P250	● P240 P250	P250	● P250	DD
3500	HG-UR352 (B)	2000			P240	P240	P240	P240	● P240 P250	● P240 P250	● P240 P250	P250	P250	P250	-	DD
5000	HG-UR502 (B)	2000	P240	P240	P240	P240	● P240 P250	● P240 P250	● P240 P250	P250	P250	P250	P250	● P250	-	DD

Refer Note 3 "-" N/A

- Note) 1. Refer to Selection Table 3 (on pages 14-17) for rated torque, allowable maximum input speed, allowable peak torque, and allowable radial and axial load for each frame size.  
 2. Refer to Selection Table 3 (on pages 14-15) for allowable acceleration or deceleration peak torque for combinations marked ●.  
 3. Smaller frame size (P1 series) is recommended when using combination with , please refer the catalog for IB series P1 type (catalog no. Z2004E).  
 4. Confirm no-load running torque when models   is selected. If it has large no-load running torque, consider to use IB-P1 type.

# Selection Table 2 (Frame Size Combination Table for Each Servo Motor Manufactures)

## 3. Yaskawa Electric Corporation

### Σ-7 Series SGM7A model (Rated speed: 3000r/min)

Servo Motor Capacity (W)	Nomenclature of Servo Motor		Reduction Ratio													Motor Flange Code
	Type	Rated Speed (r/min)	4	5	7	10	16	20	25	28	35	40	50	70	100	
1500	SGM7A-15A	3000							P240	P240	P240	P240	P240	P240	P250	1L
2000	SGM7A-20A	3000						P240	P240	P240	P240	P240	P240	● P240 P250	P250	1L
2500	SGM7A-25A	3000				P240	P240	P240	P240	P240	P240	P240	● P240 P250	● P240 P250	P250	1L
3000	SGM7A-30A	3000				P240	P240	P240	P240	P240	P240	● P240 P250	● P240 P250	P250	● P250	1T

### Σ-7 Series SGM7G model (Rated speed: 1500r/min)

Servo Motor Capacity (W)	Nomenclature of Servo Motor		Reduction Ratio													Motor Flange Code
	Type	Rated Speed (r/min)	4	5	7	10	16	20	25	28	35	40	50	70	100	
850	SGM7G-09A	1500							P240	P240	P240	P240	P240	P240	-	7Z
															P250	DA
1300	SGM7G-13A	1500						P240	P240	P240	P240	P240	● P240 P250	● P240 P250	-	7Z
															P250	DA
1800	SGM7G-20A	1500			P240	P240	P240	P240	P240	P240	P240	● P240 P250	● P240 P250	-	-	7Z
															P250	● P250

Refer Note 3 "-"/N/A

- Note) 1. Refer to Selection Table 3 (on pages 14-17) for rated torque, allowable maximum input speed, allowable peak torque, and allowable radial and axial load for each frame size.  
 2. Refer to Selection Table 3 (on pages 14-15) for allowable acceleration or deceleration peak torque for combinations marked ●.  
 3. Smaller frame size (P1 series) is recommended when using combination with , please refer the catalog for IB series P1 type (catalog no. Z2004E).

# Selection Table 2 (Frame Size Combination Table for Each Servo Motor Manufactures)

## 4. Sanyo Denki Co., Ltd.

### SANMOTION R Series

#### R2 Series (Rated speed: 2000/1500/1000r/min)

Servo Motor Capacity (W)	Nomenclature of Servo Motor		Reduction Ratio													Motor Flange Code
	Type	Rated Speed (r/min)	4	5	7	10	16	20	25	28	35	40	50	70	100	
2000	R2AA13200L	2000				P240	P240	P240	P240	P240	P240	P240	● P240 P250	P250	P250	1T
	R2AA13200D	2000				P240	P240	P240	P240	P240	P240	● P240 P250	● P240 P250	P250	● P250	1T
3500	R2AA18350L	2000			P240	P240	P240	P240	● P240 P250	● P240 P250	● P240 P250	P250	P250	P250	-	OX
	R2AA22350L	2000			P240	P240	P240	P240	● P240 P250	● P240 P250	● P240 P250	P250	P250	P250	-	DD
	R2AA18350D	2000			P240	P240	P240	● P240 P250	● P240 P250	● P240 P250	● P240 P250	P250	P250	● P250	-	OX
4500	R2AA18450H	2000	P240	P240	P240	● P240 P250	● P240 P250	● P240 P250	● P240 P250	● P240 P250	P250	P250	● P250	● P250	-	OX
5000	R2AA22500L	2000	P240	P240	P240	● P240 P250	● P240 P250	● P240 P250	● P240 P250	P250	P250	P250	● P250	● P250	-	DD
5500	R2AA18550R	1500	P240	P240	P240	● P240 P250	● P240 P250	P250	P250	P250	P250	P250	● P250	-	-	DE
	R2AA18550H	1500	P240	P240	P240	● P240 P250	● P240 P250	P250	P250	P250	● P250	● P250	● P250	-	-	DE
7000	R2AA22700S	1000	P240	P240	● P240 P250	P250	P250	P250	● P250	-	-	-	-	-	-	DK
7500	R2AA18750H	1500	P240	P240	P240	P250	P250	P250	P250	● P250	● P250	-	-	-	-	DE
11000	R2AA1811KR	1500	P240	P240	● P240 P250	P250	P250	P250	● P250	-	-	-	-	-	-	DE
	R2AA2211KB	1500	P240	P240	● P240 P250	P250	P250	P250	● P250	-	-	-	-	-	-	DK
15000	R2AA2215KB	1500	P240	● P240 P250	P250	P250	P250	-	-	-	-	-	-	-	-	DK
20000	R2AA2220KB	1500	● P240 P250	P250	P250	-	-	-	-	-	-	-	-	-	-	DK
25000	R2AA2225KB	1500	P250	P250	P250	-	-	-	-	-	-	-	-	-	-	DK

### SANMOTION R Series

#### R1 Series (Rated speed: 1500r/min)

Servo Motor Capacity (W)	Nomenclature of Servo Motor		Reduction Ratio													Motor Flange Code
	Type	Rated Speed (r/min)	4	5	7	10	16	20	25	28	35	40	50	70	100	
5500	R1AA18550H	1500	P240	P240	P240	● P240 P250	● P240 P250	P250	P250	P250	● P250	● P250	● P250	-	-	DE
7500	R1AA18750H	1500	P240	P240	P240	P250	P250	P250	P250	● P250	● P250	-	-	-	-	DE
11000	R1AA1811KR	1500	P240	P240	● P240 P250	P250	P250	● P250	● P250	-	-	-	-	-	-	DE
15000	R1AA1815KB	1500	P240	● P240 P250	P250	● P250	P250	-	-	-	-	-	-	-	-	DJ
20000	R1AA2220KB	1500	P250	P250	P250	-	-	-	-	-	-	-	-	-	-	DK

Refer Note 3 "-" N/A

- Note) 1. Refer to Selection Table 3 (on pages 14-17) for rated torque, allowable maximum input speed, allowable peak torque, and allowable radial and axial load for each frame size.  
 2. Refer to Selection Table 3 (on pages 14-15) for allowable acceleration or deceleration peak torque for combinations marked ●.  
 3. Smaller frame size (P1 series) is recommended when using combination with , please refer the catalog for IB series P1 type (catalog no. Z2004E).

# Selection Table 2 (Frame Size Combination Table for Each Servo Motor Manufactures)

## 5. Panasonic Corporation

### MDME Type (Rated speed: 2000r/min)

\*The reduction ratios with ● are possible at rated torque

Servo Motor Capacity (W)	Nomenclature of Servo Motor		Reduction Ratio													Motor Flange Code
	Type	Rated Speed (r/min)	4	5	7	10	16	20	25	28	35	40	50	70	100	
3000	MDME	2000			P240	P240	P240	P240	P240	● P240 P250	● P240 P250	P250	P250	P250	-	DA
4000	MDME	2000			P240	P240	P240	● P240 P250	● P240 P250	● P240 P250	P250	P250	P250	● P250	-	0X
5000	MDME	2000	P240	P240	P240	P240	● P240 P250	● P240 P250	● P240 P250	P250	P250	P250	P250	● P250	-	0X

### MDME Type (Rated speed: 1500r/min)

Servo Motor Capacity (W)	Nomenclature of Servo Motor		Reduction Ratio													Motor Flange Code
	Type	Rated Speed (r/min)	4	5	7	10	16	20	25	28	35	40	50	70	100	
7500	MDME	1500	P240	P240	P240	P250	P250	P250	P250	P250	● P250	-	-	-	-	DE
11000	MDME	1500	P240	P240	● P240 P250	P250	P250	P250	● P250	-	-	-	-	-	-	DL
15000	MDME	1500	P240	● P240 P250	P250	● P250	P250	-	-	-	-	-	-	-	-	DL

### MFME Type (Rated speed: 2000r/min)

Servo Motor Capacity (W)	Nomenclature of Servo Motor		Reduction Ratio													Motor Flange Code
	Type	Rated Speed (r/min)	4	5	7	10	16	20	25	28	35	40	50	70	100	
1500	MFME	2000						P240	P240	P240	P240	P240	P240	● P240 P250	P250	0X
2500	MFME	2000			P240	P240	P240	P240	P240	P240	P240	● P240 P250	● P240 P250	P250	● P250	DD
4500	MFME	2000	P240	P240	P240	P240	P240	P240	● P240 P250	● P240 P250	P250	P250	P250	● P250	-	DD

### MGME Type (Rated speed: 1000r/min)

Servo Motor Capacity (W)	Nomenclature of Servo Motor		Reduction Ratio													Motor Flange Code
	Type	Rated Speed (r/min)	4	5	7	10	16	20	25	28	35	40	50	70	100	
2000	MGME	1000			P240	P240	P240	P240	● P240 P250	● P240 P250	P250	P250	P250	P250	-	0X
3000	MGME	1000	P240	P240	P240	P240	● P240 P250	● P240 P250	P250	P250	P250	P250	P250	-	-	0X
4500	MGME	1000	P240	P240	P240	P250	P250	P250	P250	P250	● P250	● P250	-	-	-	DE
6000	MGME	1000	P240	P240	● P240 P250	P250	P250	P250	P250	● P250	-	-	-	-	-	DE

### MHME Type (Rated speed: 2000r/min)

Servo Motor Capacity (W)	Nomenclature of Servo Motor		Reduction Ratio													Motor Flange Code
	Type	Rated Speed (r/min)	4	5	7	10	16	20	25	28	35	40	50	70	100	
2000	MHME	2000				P240	P240	P240	P240	P240	P240	● P240 P250	● P240 P250	P250	● P250	0X
3000	MHME	2000			P240	P240	P240	P240	P240	● P240 P250	● P240 P250	P250	P250	P250	-	0X
4000	MHME	2000			P240	P240	P240	● P240 P250	● P240 P250	● P240 P250	P250	P250	P250	● P250	-	0X
5000	MHME	2000	P240	P240	P240	P240	● P240 P250	● P240 P250	● P240 P250	P250	P250	P250	P250	● P250	-	0X

Refer Note 3 "- " N/A

- Note) 1. Refer to Selection Table 3 (on pages 14-17) for rated torque, allowable maximum input speed, allowable peak torque, and allowable radial and axial load for each frame size.  
 2. Refer to Selection Table 3 (on pages 14-15) for allowable acceleration or deceleration peak torque for combinations marked ●.  
 3. Smaller frame size (P1 series) is recommended when using combination with , please refer the catalog for IB series P1 type (catalog no. Z2004E).

# Selection Table 2 (Frame Size Combination Table for Each Servo Motor Manufactures)

## MHME Type (Rated speed: 1500r/min)

Servo Motor Capacity (W)	Nomenclature of Servo Motor		Reduction Ratio													Motor Flange Code
	Type	Rated Speed (r/min)	4	5	7	10	16	20	25	28	35	40	50	70	100	
7500	MHME	1500	P240	P240	P240	P250	P250	P250	P250	P250	● P250	-	-	-	-	DE

## MSME Type (Rated speed: 3000r/min)

Servo Motor Capacity (W)	Nomenclature of Servo Motor		Reduction Ratio													Motor Flange Code
	Type	Rated Speed (r/min)	4	5	7	10	16	20	25	28	35	40	50	70	100	
4000	MSME (middle capacity)	3000			P240	P240	P240	P240	P240	P240	● P240 P250	● P240 P250	P250	P250	-	DA
5000	MSME (middle power)	3000			P240	P240	P240	P240	● P240 P250	● P240 P250	● P240 P250	P250	P250	P250	-	DA

Refer Note 3 "-" N/A

- Note) 1. Refer to Selection Table 3 (on pages 14-17) for rated torque, allowable maximum input speed, allowable peak torque, and allowable radial and axial load for each frame size.  
 2. Refer to Selection Table 3 (on pages 14-15) for allowable acceleration or deceleration peak torque for combinations marked ●.  
 3. Smaller frame size (P1 series) is recommended when using combination with , please refer the catalog for IB series P1 type (catalog no. Z2004E).

# Selection Table 3 (Rating Table)

Input Speed (r/min)		6000		5000		4000		3000		2500	
Frame Size	Reduction Ratio	Rated torque	Allowable input power	Rated torque	Allowable input power	Rated torque	Allowable input power	Rated torque	Allowable input power	Rated torque	Allowable input power
		(N·m)	(kW)	(N·m)	(kW)	(N·m)	(kW)	(N·m)	(kW)	(N·m)	(kW)
P240	4					366	40.3	398	32.9	421	29.0
	5					366	32.2	398	26.4	421	23.2
	7					386	24.3	421	19.9	444	17.5
	10			284	15.7	304	13.4	331	11.0	350	9.6
	16	386	16.8	408	14.8	436	12.7	475	10.4	475	8.8
	20	386	13.5	408	11.9	436	10.1	475	8.3	475	7.1
	25	406	11.3	429	10.0	459	8.5	500	7.0	500	5.9
	28	406	10.1	429	8.9	459	7.6	500	6.2	500	5.3
	35	406	8.1	429	7.1	459	6.1	500	5.0	500	4.2
	40	374	6.5	395	5.7	422	4.9	460	4.0	460	3.4
	50	406	5.7	429	5.0	459	4.3	500	3.5	500	3.0
	70	406	4.1	429	3.6	459	3.0	500	2.5	500	2.1
100	284	2.0	300	1.7	321	1.5	350	1.2	350	1.0	
P250	4							1007	83.3	1064	73.3
	5							1007	66.6	1064	58.6
	7							1056	49.9	1115	43.9
	10					812	35.8	885	29.3	935	25.8
	16					1303	37.9	1420	31.0	1500	27.3
	20					1303	30.3	1420	24.8	1500	21.8
	25					1303	24.3	1420	19.8	1500	17.5
	28					1303	21.7	1420	17.7	1500	15.6
	35					1303	17.3	1420	14.2	1500	12.5
	40			1137	16.5	1216	14.1	1325	11.6	1400	10.2
	50			1287	15.0	1376	12.8	1500	10.5	1500	8.9
	70			1287	10.7	1376	9.1	1500	7.5	1500	6.4
100			858	5.0	917	4.3	1000	3.5	1000	3.0	

Light Blue : Allowable continuous operation period: maximum 5min., 30%ED

Dark Blue : Allowable continuous operation period: maximum 10min., 50%ED

Note) 1. **Rated output torque**

Rated output torque implies allowable mean load torque at each input speed. Rated output torque for below 1500r/min input speed is the same as 1500r/min.

Allowable input power is the value converted from rated output torque, when it is 100%. This value is in consideration of efficiency.

2. **Allowable maximum input speed and allowable mean input speed**

Reducer may be used within maximum input speed indicated in the Table above, however, allowable mean input speed is limited by operation rate (%ED).

3. **Allowable acceleration or deceleration peak torque**

Allowable peak torque at normal start and stop.

4. **Allowable maximum momentary torque**

Allowable maximum momentary torque at emergency stop or heavy shock, when loading 1000 times in overall lifetime.

5. Rated torque which is not shown in the rating table can be calculated by using below formula.

$$T_1 = T_0 \left( \frac{N_0}{N_1} \right)^{0.3}$$

T<sub>1</sub> : Calculated rated torque (N·m)

N<sub>1</sub> : Average input speed (r/min)

T<sub>0</sub> : Rated torque from rating table at input speed which is close to N<sub>1</sub> (N·m)

N<sub>0</sub> : Input speed related to T<sub>0</sub> from rating table (r/min)

Rated torque under allowable mean input speed is same as the torque at allowable mean input speed.

# Selection Table 3 (Rating Table)

2000		1500		1000		Allowable acceleration or deceleration peak torque (N-m)	Allowable maximum momentary torque (N-m)	Allowable maximum input speed (r/min)	Allowable mean input speed (r/min)	Reduction Ratio	Frame Size
Rated torque (N-m)	Allowable input power (kW)	Rated torque (N-m)	Allowable input power (kW)	Rated torque (N-m)	Allowable input power (kW)						
450	24.8	450	19.2	450	13.4	900	1500	4000	2000	4	P240
450	19.8	450	15.4	450	10.7	900	1500	4000	2000	5	
475	15.0	475	11.6	475	8.1	900	1500	4000	2000	7	
350	7.9	350	6.1	350	4.3	650	1050	5000	2500	10	
475	7.2	475	5.6	475	3.9	900	1500	6000	3000	16	
475	5.8	475	4.5	475	3.1	900	1500	6000	3000	20	
500	4.9	500	3.8	500	2.6	900	1500	6000	3000	25	
500	4.3	500	3.4	500	2.3	900	1500	6000	3000	28	
500	3.5	500	2.7	500	1.9	900	1500	6000	3000	35	
460	2.8	460	2.2	460	1.5	900	1500	6000	3000	40	
500	2.4	500	1.9	500	1.3	900	1500	6000	3000	50	
500	1.7	500	1.3	500	0.9	900	1500	6000	3000	70	
350	0.9	350	0.7	350	0.5	650	1050	6000	3000	100	
1137	62.7	1240	51.3	1240	35.8	3000	5250	3000	1500	4	
1137	50.2	1240	41.0	1240	28.6	3000	5250	3000	1500	5	
1193	37.6	1300	30.7	1300	21.4	3000	5250	3000	1500	7	
1000	22.0	1000	17.1	1000	11.9	2000	3150	4000	2000	10	
1500	22.4	1500	17.3	1500	12.1	3000	5250	4000	2500	16	
1500	17.9	1500	13.9	1500	9.7	3000	5250	4000	2500	20	
1500	14.3	1500	11.1	1500	7.7	3000	5250	4000	2500	25	
1500	12.8	1500	9.9	1500	6.9	3000	5250	4000	2500	28	
1500	10.2	1500	7.9	1500	5.5	3000	5250	4000	2500	35	
1400	8.4	1400	6.5	1400	4.5	3000	5250	5000	2500	40	
1500	7.3	1500	5.7	1500	3.9	3000	5250	5000	3000	50	
1500	5.2	1500	4.0	1500	2.8	3000	5250	5000	3000	70	
1000	2.4	1000	1.9	1000	1.3	2000	3150	5000	3000	100	

: Allowable continuous operation period: maximum 20min., 60%ED

: Allowable continuous operation period: maximum 30min., 80%ED

# Selection Table 3 (Allowable External Rating)

Input Speed (r/min)		6000		5000		4000		3000	
Frame Size	Reduction Ratio	Radial Load <sup>(Note)1</sup> (N)	Axial Load <sup>(Note)2</sup> (N)	Radial Load <sup>(Note)1</sup> (N)	Axial Load <sup>(Note)2</sup> (N)	Radial Load <sup>(Note)1</sup> (N)	Axial Load <sup>(Note)2</sup> (N)	Radial Load <sup>(Note)1</sup> (N)	Axial Load <sup>(Note)2</sup> (N)
P240	4					3150	5200	3465	5200
	5					3390	5200	3730	5200
	7					3790	5200	4175	5200
	10			3965	5200	4270	5200	4700	5200
	16	4365	5200	4640	5200	5000	5200	5495	5200
	20	4705	5200	4995	5200	5380	5200	5925	5200
	25	5065	5200	5385	5200	5800	5200	6385	5200
	28	5260	5200	5590	5200	6020	5200	6630	5200
	35	5665	5200	6020	5200	6485	5200	7140	5200
	40	5920	5200	6295	5200	6780	5200	7465	5200
	50	6380	5200	6785	5200	7305	5200	8045	5200
	70	7140	5200	7590	5200	8175	5200	9000	5200
100	8045	5200	8545	5200	9210	5200	10135	5200	
P250	4							5440	8100
	5							5860	8100
	7							6555	8100
	10					6705	8100	7385	8100
	16					7840	8100	8635	8100
	20					8450	8100	9305	8100
	25					9105	8100	10020	8100
	28					9460	8100	10410	8100
	35					10185	8100	11210	8100
	40			9885	8100	10650	8100	11725	8100
	50			10650	8100	11470	8100	12630	8100
	70			11915	8100	12835	8100	14130	8100
100			13420	8100	14460	8100	15915	8100	

- Note) 1. Radial load is the value applied to the position 30mm from the end face of output shaft flange. (with no axial load)  
 Multiply radial load locating factor to the value in the above table when the radial load is applied to locations other than the position 30mm from the end face of the output shaft flange.
2. Axial load is the value applied to the center of the output flange. (with no radial load)

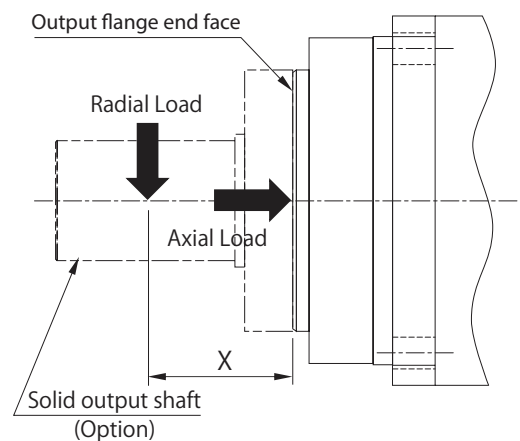
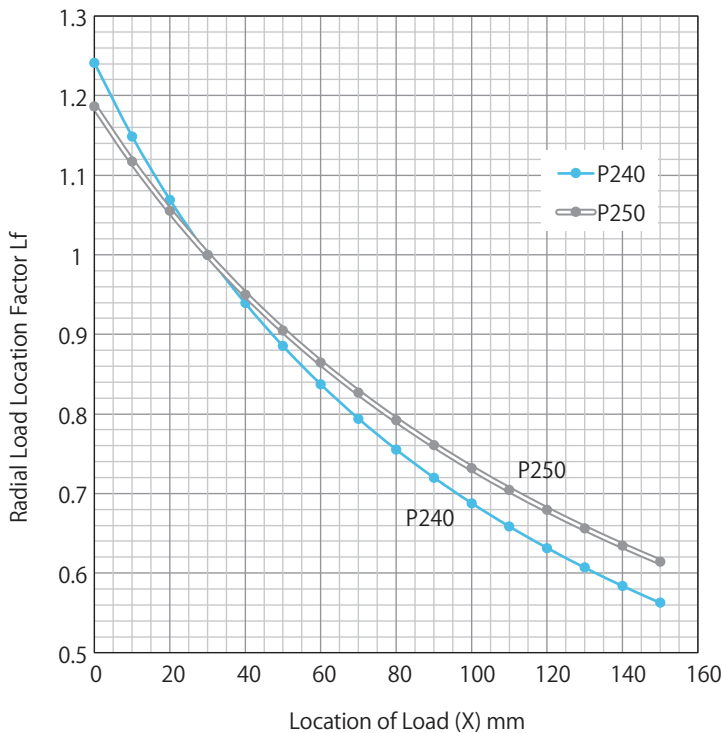

Figure 1 Radial Load Location Factor

# Selection Table 3 (Allowable External Rating)

2500		2000		1500		1000		Input Speed (r/min)	
Radial Load <sup>(Note)1</sup> (N)	Axial Load <sup>(Note)2</sup> (N)	Radial Load <sup>(Note)1</sup> (N)	Axial Load <sup>(Note)2</sup> (N)	Radial Load <sup>(Note)1</sup> (N)	Axial Load <sup>(Note)2</sup> (N)	Radial Load <sup>(Note)1</sup> (N)	Axial Load <sup>(Note)2</sup> (N)	Reduction Ratio	Frame Size
3680	5200	3965	5200	4365	5200	5000	5200	4	P240
3960	5200	4270	5200	4700	5200	5385	5200	5	
4435	5200	4780	5200	5260	5200	6025	5200	7	
4995	5200	5385	5200	5925	5200	6785	5200	10	
5840	5200	6295	5200	6930	5200	7935	5200	16	
6295	5200	6785	5200	7465	5200	8550	5200	20	
6785	5200	7300	5200	8045	5200	9200	5200	25	
7045	5200	7575	5200	8355	5200	9550	5200	28	
7590	5200	8175	5200	9000	5200	10245	5200	35	
7935	5200	8550	5200	9410	5200	10245	5200	40	
8545	5200	9210	5200	10135	5200	10245	5200	50	
9565	5200	10245	5200	10245	5200	10245	5200	70	
10245	5200	10245	5200	10245	5200	10245	5200	100	
5780	8100	6230	8100	6855	8100	7850	8100	4	P250
6225	8100	6710	8100	7385	8100	8455	8100	5	
6965	8100	7505	8100	8260	8100	9460	8100	7	
7845	8100	8455	8100	9305	8100	10655	8100	10	
9175	8100	9885	8100	10880	8100	12460	8100	16	
9885	8100	10655	8100	11725	8100	13425	8100	20	
10650	8100	11475	8100	12630	8100	14460	8100	25	
11065	8100	11920	8100	13120	8100	15020	8100	28	
11915	8100	12835	8100	14130	8100	16175	8100	35	
12460	8100	13425	8100	14775	8100	16915	8100	40	
13420	8100	14460	8100	15915	8100	18220	8100	50	
15015	8100	16175	8100	17805	8100	18385	8100	70	
16915	8100	18220	8100	18385	8100	18385	8100	100	

When a gear or sheave is mounted on the output shaft, radial load and axial load should be equal to or less than allowable value. Check radial & axial load by following the next formulas (1 to 3).

(1) Radial load  $P_r$

$$P_r = \frac{T\ell}{R} \leq \frac{P_{ro} \cdot L_f}{C_f \cdot F_{s1}} \text{ [N]}$$

$P_r$  : Actual radial load [N]  
 $T\ell$  : Equivalent torque on output shaft [N·m]  
 $R$  : Pitch circle radius of sprocket, gear, or sheave [m]  
 $P_{ro}$  : Allowable radial load [N] (Selection Table 3 P.16, 17)

(2) Axial load  $P_a$

$$P_a \leq \frac{P_{ao}}{C_f \cdot F_{s1}} \text{ [N]}$$

$P_a$  : Actual axial load [N]  
 $P_{ao}$  : Allowable axial load [N] (Selection Table 3 P.16, 17)

(3) When radial and axial load co-exist

$$\left( \frac{P_r}{P_{ro} \cdot L_f} + \frac{P_a}{P_{ao}} \right) \cdot C_f \cdot F_{s1} \leq 1$$

$L_f$  : Radial Load Location factor (Fig.1 P.16)  
 $C_f$  : Load location factor (Table 1)  
 $F_{s1}$  : Shock factor (Table 2)

Table 1 Load location factor  $C_f$

Connection method	$C_f$
General purpose chain	1.00
Machine gear or pinion	1.25
Belt	1.50

Table 2 Shock factor  $F_{s1}$

Shock classification	$F_{s1}$
Uniform load (no shock)	1
Moderate shocks	1 - 1.2
Heavy shocks	1.4 - 1.6

# Selection Procedure

## Flow Chart and Formula of Selection

Fig. 2 Load Pattern

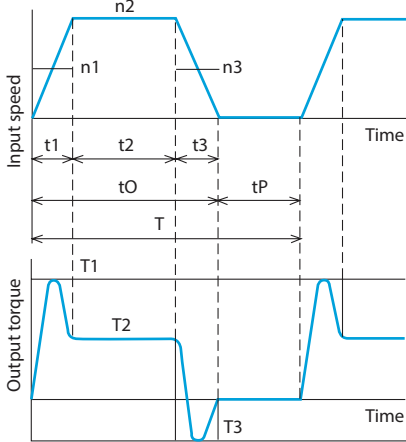

$n_1$ : Average Input speed at acceleration  
 e.g. Fig.2:  $n_1 = \frac{n_2}{2}$  (r/min)  
 $n_2$ : Input speed at normal operation  
 $n_3$ : Average input speed at deceleration  
 e.g. Fig.2:  $n_1 = n_3 = \frac{n_2}{2}$  (r/min)

$t_1$ : Acceleration time [s]  
 $t_2$ : Steady operation time [s]  
 $t_3$ : Deceleration time [s]  
 $t_0$ : Operation time [s]  
 $t_P$ : Stop time [s]  
 $T$ : Operation cycle [s]

$T_1$ : Starting peak torque [N·m]  
 $T_2$ : Steady operation torque [N·m]  
 $T_3$ : Stopping peak torque [N·m]

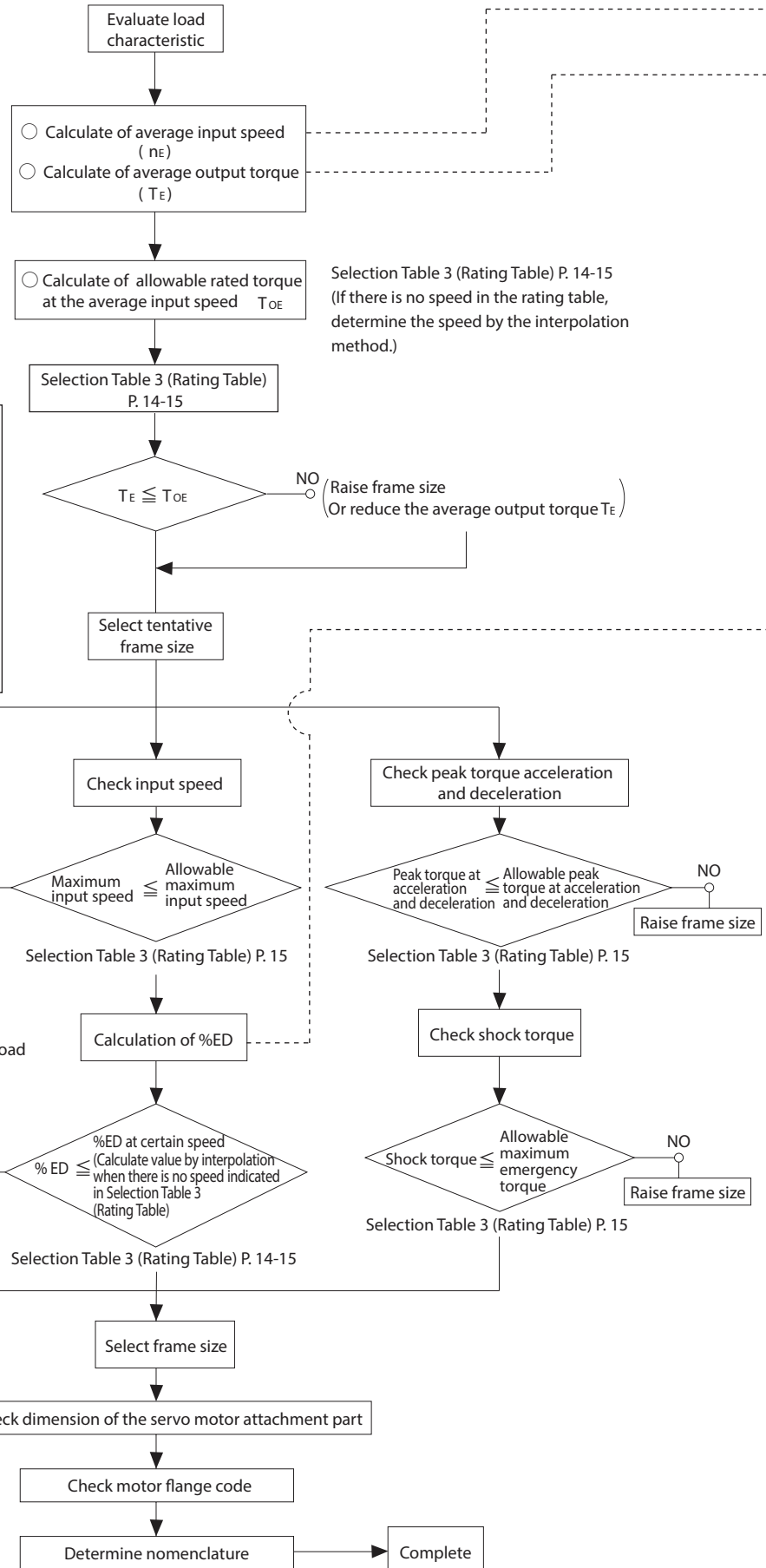

# Selection Procedure

Calculation in Load Pattern of Fig.2

○ Average input speed  $n_E = \frac{t_1 \cdot n_1 + t_2 \cdot n_2 + t_3 \cdot n_3 + \dots + t_n \cdot n_n}{t_o}$  ..... Formula 1  $n=4,5,6 \dots$

○ Average output torque  $T_E = \left( \frac{t_1 \cdot n_1 \cdot T_1^{10/3} + t_2 \cdot n_2 \cdot T_2^{10/3} + t_3 \cdot n_3 \cdot T_3^{10/3} + \dots + t_n \cdot n_n \cdot T_n^{10/3}}{t_o \cdot n_E} \right)^{0.3} \times F_{s2}$  ..... Formula 2  $n=4,5,6 \dots$   
(Table 3)

○ %ED  $\% ED = \frac{t_o}{T} \times 100$  ..... Formula 3

%ED Calculation at Average Input Speed Interpolation method

$$\%ED(x) = \frac{y_i(x-x_{i+1}) - y_{i+1}(x-x_i)}{x_i - x_{i+1}}$$

- %ED(x) : Calculated %ED
- x : Average input speed
- $x_i$  : Speed lower than the average input speed on the rating table
- $y_i$  : Allowable %ED at the above speed
- $x_{i+1}$  : Speed higher than the average input speed on the rating table
- $y_{i+1}$  : Allowable %ED at the above-mentioned speed

Table 3 F<sub>s2</sub> Load factor

Load condition	F <sub>s2</sub>
Uniform load (no shock)	1
Moderate shocks	1 - 1.2
Heavy shocks	1.4 - 1.6

## Example of Selection

Evaluate ANFX-P240F-0XL3-16 for following specification.

- |   |           |  |      |
|---|-----------|--|------|
| (Specifications) T <sub>A</sub> : Acceleration peak time  | 800N·m    | t <sub>A</sub> : Acceleration time                 | 0.2s |
| T <sub>R</sub> : Normal running torque                    | 300N·m    | t <sub>R</sub> : Normal running time               | 5.0s |
| T <sub>B</sub> : Peak torque at breaking                  | 600N·m    | t <sub>B</sub> : Deceleration time                 | 0.2s |
| Shock torque: 1000N·m (700 times during overall lifetime) |           | t <sub>P</sub> : Standstill time                   | 4.0s |
| n <sub>A</sub> : Average Input speed during acceleration  | 1500r/min | t <sub>O</sub> : Running time                      | 5.4s |
| n <sub>R</sub> : Input speed with normal running          | 3000r/min | T : Single cycle time                              | 9.4s |
| n <sub>B</sub> : Average Input speed during deceleration  | 1500r/min | Output shaft radial load: Belt drive, Small impact |      |

to the position 60mm from the flange surface

There shall be almost no shock in application 3500N

(Calculation) Average input speed  $n_E = \frac{0.2 \times 1500 + 5.0 \times 3000 + 0.2 \times 1500}{5.4} = 2889 \text{ (r/min)}$

Average output torque  $T_E = \left( \frac{0.2 \times 1500 \times 800^{10/3} + 5.0 \times 3000 \times 300^{10/3} + 0.2 \times 1500 \times 600^{10/3}}{5.4 \times 2889} \right)^{0.3} \times 1 = 349.3 \text{ N·m}$

- Allowable rating output torque at average input speed Select ANFX-P240F-0XL3-16 temporarily.  
Since the allowable average input speed is 3000 (r/min), the allowable average output torque is 475N·m.
- Check Average output torque  $349.3 < 475.0 \dots \text{OK}$
- Calculate %ED  $\% ED = \frac{5.4}{9.4} \times 100 = 57.4\%$
- Continuous running time  $10 \text{ min} = 600 \text{ s} > 5.4 \text{ s} \dots \text{OK}$
- $\frac{80 \times (2889 - 3000) - 60 \times (2889 - 2500)}{2500 - 3000} \doteq 64.4$   
 $64.4\% > 57.4\% \dots \text{OK}$
- Check Maximum input speed  $3000 \text{ r/min} < 6000 \text{ r/min}$
- Check allowable acceleration or deceleration peak torque  $800 \text{ N·m} < 900 \text{ N·m}$
- Check shock torque  $1000 \text{ N·m} < 1500 \text{ N·m}$  (1000 times during overall lifetime)
- Allowable output shaft radial load considering factors

Selection Table 3 (Rating Table) P. 15

Pro = 5495N, Lf = 0.84, CF = 1.5, F<sub>s1</sub> = 1.2  $\frac{\text{Pro}}{L_f \times C_f \times F_{s1}} = \frac{5495}{0.84 \times 1.5 \times 1.2} = 3,634 \quad 3,500 < 3,634$

ANFX-P240F-0XL3-16 is selected by the process above.

# Dimension Drawings

P240F Single stage type (Reduction Ratio: 4-10)

Adapter plate shape A (Square flange)

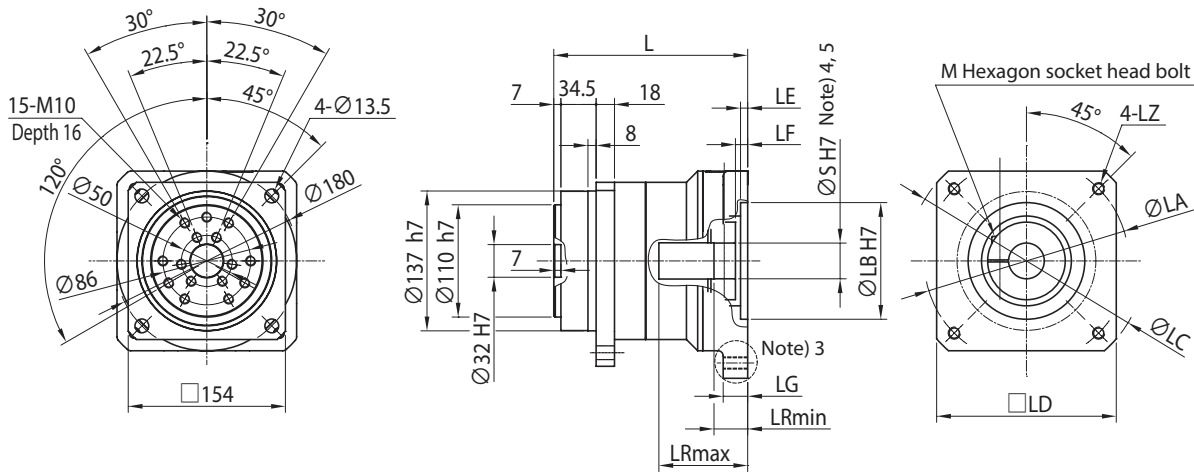

Adapter plate shape B (Round flange)

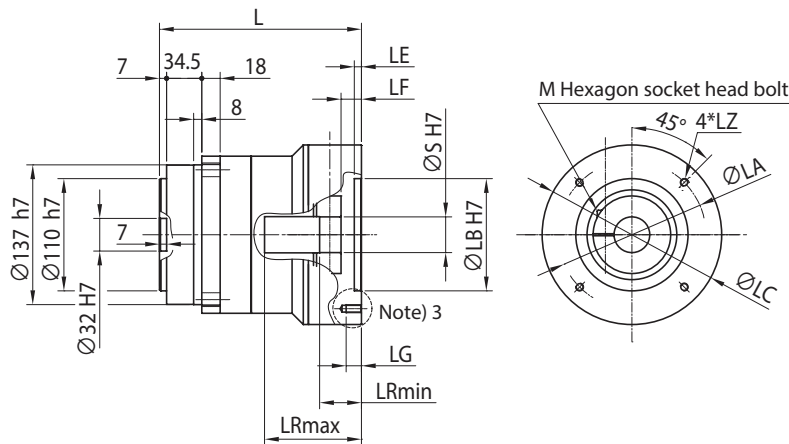

Motor flange code	Dimension															Reduction ratio	
	L	LA	LB	LC	LD	LE	LF	LG	Adapter plate shape	LZ	LR		S	M	Mass (kg)		
											max	min					
OX (Note)4	190	200	114.3	230	180	7	12	24	Useful thread length	A	M12	87	33	35	M10	19	4 - 10
1T	198	145	110	176	-	7	20	15	Useful thread length	B	M8	95	41	28	M10	20	10
DA	198	145	110	176	-	7	20	15	Useful thread length		M8	95	41	24	M10	20	10
DD (Note)4	199	235	200	270	220	7	21	24	Through hole	A	M12	96	42	35	M10	19	5 - 10
DE	221	200	114.3	233	180	6	20	24	Useful thread length		M12	118	44	42	M12	20	4 - 10
DJ	237	200	114.3	230	180	6	37	24	Useful thread length		M12	134	61	55	M12	20	4 - 5
DK	237	235	200	270	220	8	37	28	Through hole		M12	134	61	55	M12	20	4 - 7
DL (Note)5	237	235	200	270	220	8	37	28	Through hole		M12	134	61	55	M12	20	4 - 7

- Note) 1. Dimensions and mass shown in the above figures are subject to change without prior notification.  
 2. The reduction ratios in this table are based on motor combinations shown in Selection Table 2. Contact us for any combinations not shown above.  
 3. The shape of tapping hole for motor mounting is Through Hole or Useful Thread Length.  
 4. The tolerance of ØS for motor flange code OX and DD is "+0.010 to +0.035".  
 5. The tolerance of ØS for motor flange code DL is F7 (+0.030 to +0.060).

# Dimension Drawings

P240F Double stage type (Reduction Ratio: 16-100)

Adapter plate shape A (Square flange)

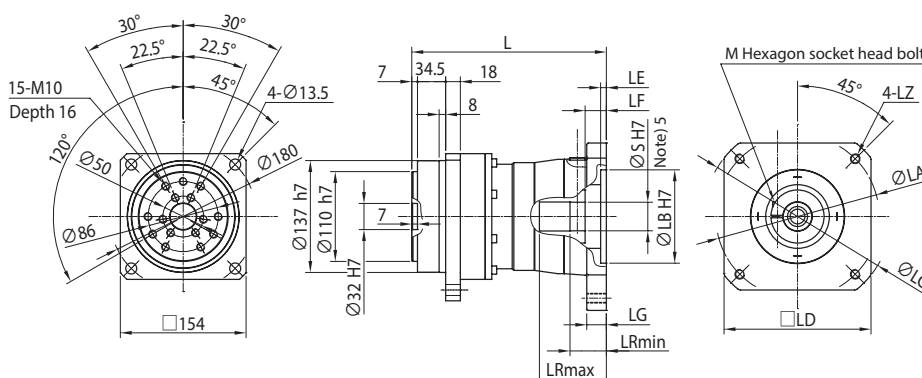

Adapter plate shape B (Round flange)

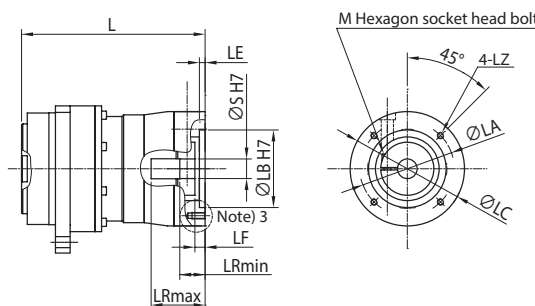

Adapter plate shape C (with flange plate)

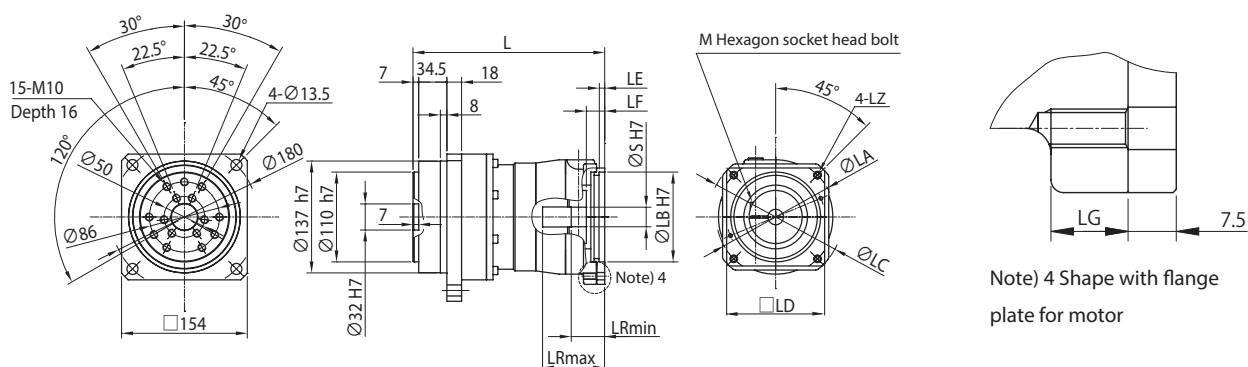

Motor flange code	Dimension															Reduction ratio	
	L	LA	LB	LC	LD	LE	LF	LG	Adapter plate shape	LZ	LR		S	M	Mass (kg)		
											max	min					
1L	225	115	95	140	-	7	12.5	12	Useful thread length	B	M6	79	31	24	M8	21	16 - 70
7Y	225	115	95	140	-	7	12.5	16			Useful thread length	A	M8	79	31	24	M8
DA	225	145	110	165	130	10	12.5	16	Useful thread length	C Note)4			M8	79	31	24	M8
7Z	235	145	110	165	130	7	22.5	16			Useful thread length	A	M8	89	41	24	M8
1T	225	145	110	165	130	10	12.5	16	Useful thread length	A			M8	66	31	28	M8
DC	238	200	114.3	230	180	7	26	24			Through hole	A	M12	79	44.5	28	M8
OX Note)5	238	200	114.3	230	180	7	26	24	Through hole	A			M12	82	44.5	35	M8
DD Note)5	238	235	200	270	220	7	26	24			Through hole	A	M12	82	44.5	35	M8
DE	237	200	114.3	230	180	7	12	24	Useful thread length	A			M12	81	33	42	M10

- Note) 1. Dimensions and mass shown in the above figures are subject to change without prior notification.  
 2. The reduction ratios in this table are based on motor combinations shown in Selection Table 2. Contact us for any combinations not shown above.  
 3. The shape of tapping hole for motor mounting is Through Hole or Useful Thread Length.  
 4. This is equipped with flange plate. Flange plate is sent as assembly parts and needs to be set by customer. (Installation method is shown at p.27)  
 5. The tolerance of ØS for motor flange code OX and DD is "+0.010 to +0.035".

# Dimension Drawings

P250F Single stage type (Reduction Ratio: 4-10)

Adapter plate shape A (Square flange)

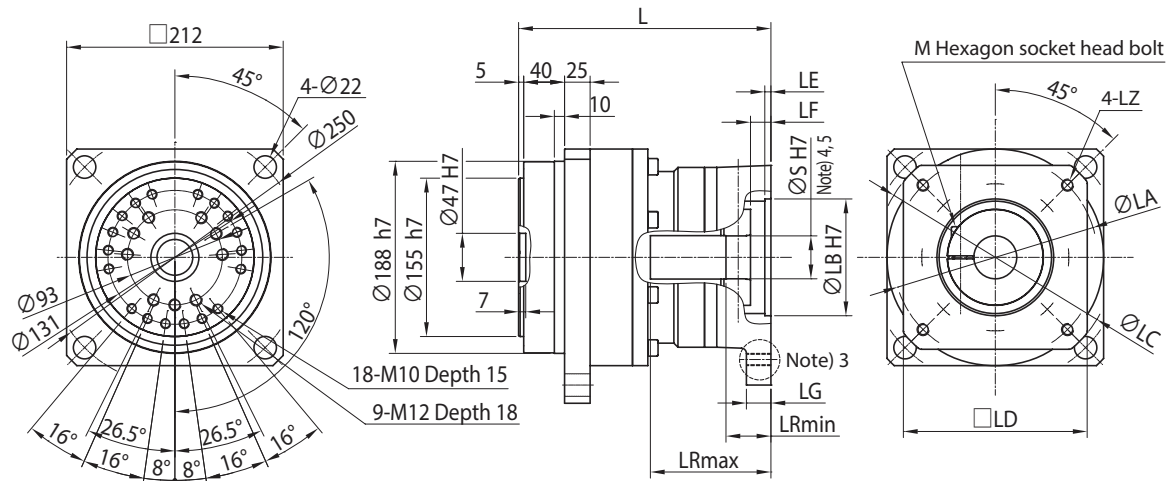

Motor flange code	Dimension														Reduction ratio	
	L	LA	LB	LC	LD	LE	LF	LG	Adapter plate shape	LZ	LR		S	M		Mass (kg)
											max	min				
OX Note)4	247	200	114.3	233	180	6	20	24	A	M12	118	44	35	M12	36	10
DE	247	200	114.3	233	180	6	20	24		M12	118	44	42	M12	35	10
DJ	258	200	114.3	230	180	6	37	24		M12	129	61	55	M12	36	7 - 10
DK	258	235	200	270	220	8	37	28		M12	129	61	55	M12	36	4 - 10
DL Note)5	258	235	200	270	220	8	37	28		M12	129	61	55	M12	36	7 - 10

Note) 1. Dimensions and mass shown in the above figures are subject to change without prior notification.

2. The reduction ratios in this table are based on motor combinations shown in Selection Table 2. Contact us for any combinations not shown above.

3. The shape of tapping hole for motor mounting is Through Hole or Useful Thread Length.

4. The tolerance of ØS for motor flange code DD is "+0.010 to +0.035".

5. The tolerance of ØS for motor flange code DL is F7 (+0.030 to +0.060).



# Nominal life calculation of Main Bearing

The main bearing of P2 Type of IB Series uses angular bearing to allow high radial load moment. Check the lifetime of the main bearing through the following calculation.

**Check Procedure**

- [1] Calculation of the equivalent radial load and equivalent axial load (Formulas (3), (4))
- ↓
- [2] Calculation of the bearing reaction force  $R_A$  and  $R_B$  (Formulas (1), (2))
- ↓
- [3] Calculation of the dynamic equivalent load (Table 6)
- ↓
- [4] Calculation of the equivalent output speed (Formula (5))
- ↓
- [5] Calculation of the bearing lifetime (Formula (6))

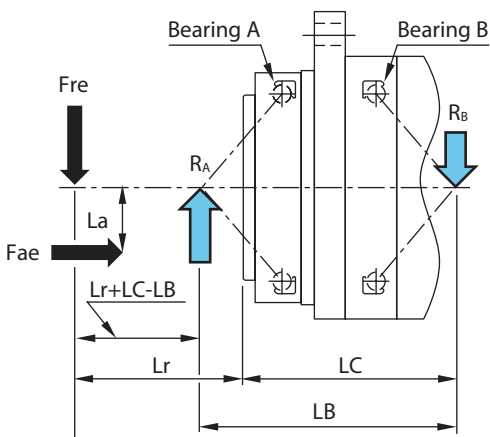

$F_{re}$  : Equivalent radial load (N)  
 $F_{ae}$  : Equivalent axial load (N)

$$R_A = \frac{F_{re} \cdot (L_r + L_C) + F_{ae} \cdot L_a}{L_B} \dots\dots\dots \text{Formula (1)}$$

$$R_B = \frac{F_{re} \cdot (L_r + L_C - L_B) + F_{ae} \cdot L_a}{L_B} \dots\dots\dots \text{Formula (2)}$$

Table 4 Span between Load Points (mm)

Frame Size	Span between Load Points	
	LB (mm)	LC (mm)
P240	147.9	124.3
P250	201.7	160.9

Figure 3 External Load Interaction Diagram

Table 5 Main Bearing Specifications

Frame Size	Dynamic rated load C (N)	Load factor				e
		X		Y		
		$F_{aA}/R_A \leq e$	$F_{aA}/R_A > e$	$F_{aB}/R_B \leq e$	$F_{aB}/R_B > e$	
P240	34900	1	0.35	0	0.57	1.14
P250	49700					

## Calculation of equivalent load

If the radial load and axial load fluctuate, confirm the lifetime converting to equivalent load.

Equivalent radial load  $F_{re}$

$$F_{re} = \sqrt[3]{\frac{n_1 \cdot t_1 \cdot (|Fr_1|)^3 + n_2 \cdot t_2 \cdot (|Fr_2|)^3 + \dots + n_n \cdot t_n \cdot (|Fr_n|)^3}{n_1 \cdot t_1 + n_2 \cdot t_2 + \dots + n_n \cdot t_n}} \dots\dots\dots \text{Formula (3)}$$

Equivalent axial load  $F_{ae}$

$$F_{ae} = \sqrt[3]{\frac{n_1 \cdot t_1 \cdot (|Fa_1|)^3 + n_2 \cdot t_2 \cdot (|Fa_2|)^3 + \dots + n_n \cdot t_n \cdot (|Fa_n|)^3}{n_1 \cdot t_1 + n_2 \cdot t_2 + \dots + n_n \cdot t_n}} \dots\dots\dots \text{Formula (4)}$$

Equivalent output speed  $N_{eo}$

$$N_{eo} = \frac{n_1 \cdot t_1 + n_2 \cdot t_2 + \dots + n_n \cdot t_n}{t_1 + t_2 + \dots + t_n} \dots\dots\dots \text{Formula (5)}$$

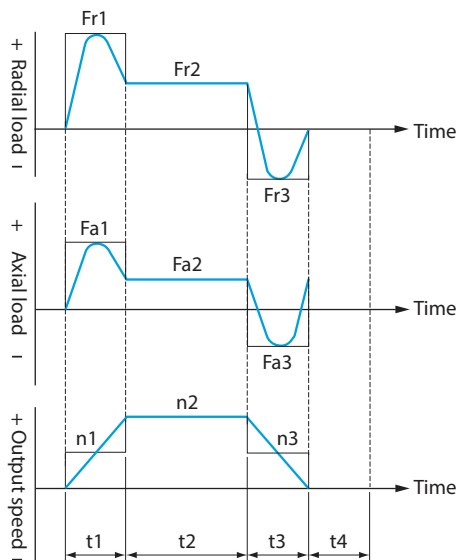

Figure 4 Example of Load Fluctuation

# Nominal life calculation of Main Bearing

Table 6 Axial Load Direction and Dynamic Equivalent Load Formula



Axial Load Direction	Load Condition	Bearing Category	Axial Load	Dynamic Equivalent Load
 (Applied to motor side)	$\frac{R_B}{2Y_2} + Fa e \geq \frac{R_A}{2Y_2}$	Bearing A	$F_{aA} = \frac{R_B}{2Y_2} + Fa e$	$P_A = X \cdot R_A + Y \cdot F_{aA}$ Note: When $P_A < R_A$ , use $P_A = R_A$
		Bearing B	—	$P_B = R_B$
	$\frac{R_B}{2Y_2} + Fa e < \frac{R_A}{2Y_2}$	Bearing A	—	$P_A = R_A$
		Bearing B	$F_{aB} = \frac{R_A}{2Y_2} - Fa e$	$P_B = X \cdot R_B + Y \cdot F_{aB}$ Note: When $P_B < R_B$ , use $P_B = R_B$ .
 (Applied to output side)	$\frac{R_B}{2Y_2} \leq \frac{R_A}{2Y_2} + Fa e$	Bearing A	—	$P_A = R_A$
		Bearing B	$F_{aB} = \frac{R_A}{2Y_2} + Fa e$	$P_B = X \cdot R_B + Y \cdot F_{aB}$ Note: When $P_B < R_A$ , use $P_B = R_A$ .
	$\frac{R_B}{2Y_2} > \frac{R_A}{2Y_2} + Fa e$	Bearing A	$F_{aA} = \frac{R_B}{2Y_2} - Fa e$	$P_A = X \cdot R_A + Y \cdot F_{aA}$ Note: When $P_A < R_A$ , use $P_A = R_A$ .
		Bearing B	—	$P_B = R_B$

Table 7 Symbols in Table 5 & 6

P	Dynamic equivalent load (Either the larger one of dynamic equivalent load $P_A$ or $P_B$ , each influencing bearing A and B)	N	Refer to Table 6
$R_A, R_B$	Support reaction applied to each bearing A and B calculated from equivalent external load $F_{re}$ and $F_{ae}$	N	—
X	Radial load factor	—	Refer to Table 5
Y	Axial load factor		
Y2	Axial load factor $Y2=0.57$ when $Fa^* / R^* > e$		
$F_{aA}, F_{aB}$	Axial load exerted on each of bearing A and B	N	—

Calculated lifetime  $L_{10h}$

$$L_{10h} = \frac{10^6}{60 \cdot Neo} \left( \frac{C}{Cf \cdot Fs \cdot P} \right)^3 \dots\dots \text{Formula (6)}$$

Table 8 Load location factor Cf

Connection method	Cf
General purpose chain	1.00
Machine gear or pinion	1.25
Belt	1.50

Table 9 Shock factor Fs

Shock classification	Fs
Uniform load (no shock)	1.0
Moderate shocks	1.0 - 1.2
Heavy shocks	1.4 - 1.6

Table 10 Symbols in Formula (6)

Neo	Equivalent output speed	r/min	Refer to formula (5)
P	Dynamic equivalent load	N	Refer to Table 6
C	Dynamic rated load	N	Refer to Table 5
Cf	Load location factor	—	Refer to Table 8
Fs	Shock factor	—	Refer to Table 9

# Specifications of Output Part of the Reducer

## Mechanical Accuracy of Output Part of the Reducer

Mechanical position accuracy of flange shaft is indicated below.

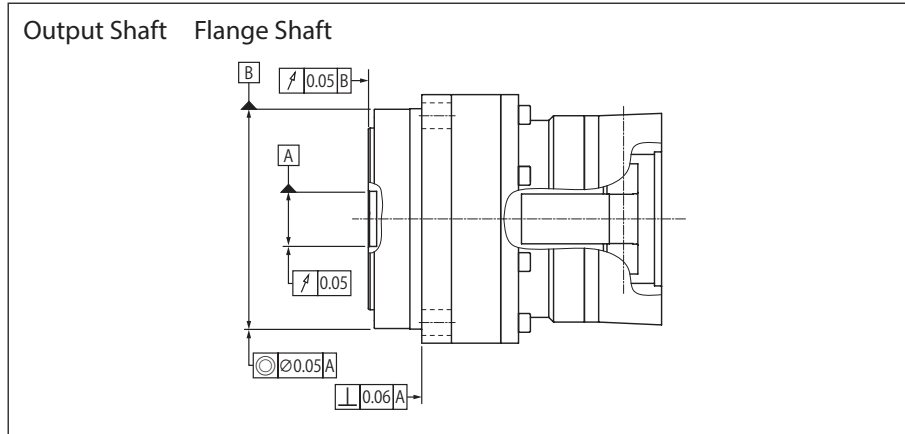

Figure 5 Mechanical Position Accuracy of Flange Shaft

## Tightening Torque and Allowable Transmitted Torque for Output Flange Bolts

The following table shows the number of bolts, size, tightening torque, and allowable transmitted torque when tightening the output flange of the reducer with bolts.

Frame Size	Bolt Number-Size	Bolt PCD mm	Bolt tightening torque		Allowable transmitted torque by bolts (for each pitch)		Allowable transmitted torque by bolts (total)	
			N·m	kgf·cm	N·m	kgf·m	N·m	kgf·m
P240	6-M10	50	65.7	670	736	75	2635	269
	9-M10	86	65.7	670	1899	194		
P250	9-M12	93	114	1160	2985	304	8770	894
	18-M10	131	65.7	670	5785	590		

- Bolt: Use hexagon socket bolts whose JIS B1176 Strength Class is 10.9.
- Locking measure: Use adhesive (Loctite 262, etc.) or conical spring washer (JIS B 1251 Class 2).
- Coefficient of friction: 0.15

## Solid Shaft Design (Option)

Solid shaft (keyless) dimensions

P240

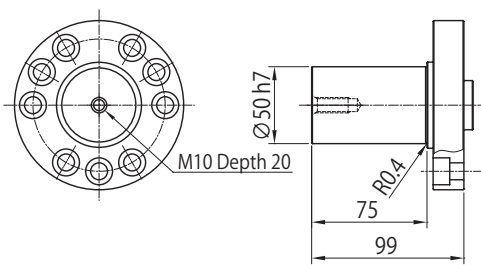

P250

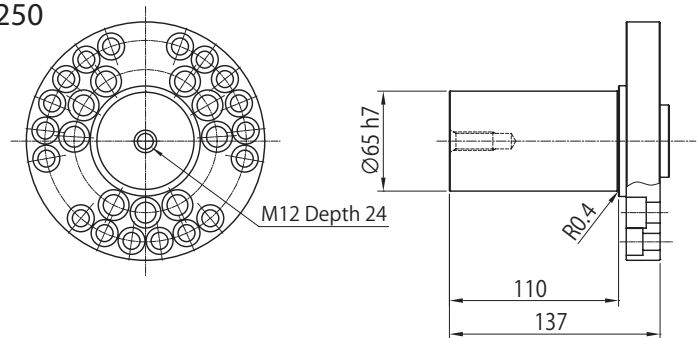

Solid shaft (with key) dimensions

P240

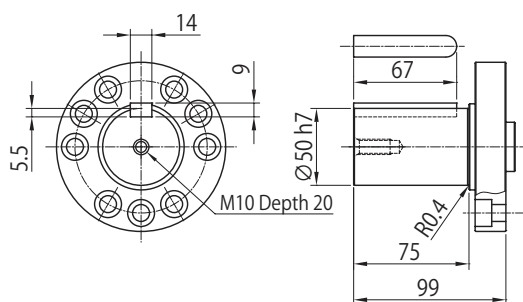

P250

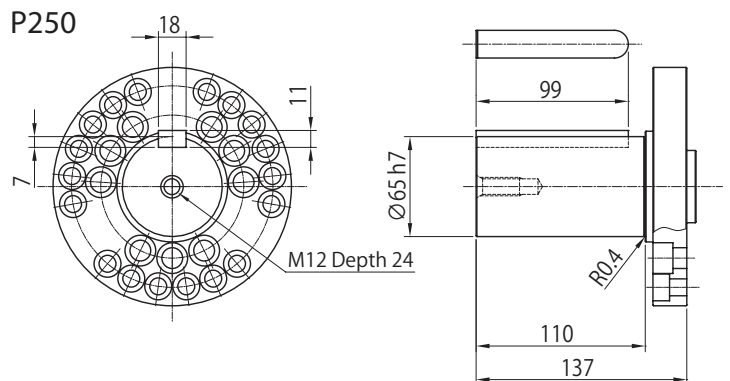

Shaft end key and keyway dimensions conform to JIS B 1301-1996 (ISO "Keys and Their Corresponding Keyways: Parallel keys (Tightening Type)").

Figure 6 Dimension Drawing of Solid Shaft (Keyless/With Key)

# Motor Installation Procedure

Straight with/without key type of motor shaft should be connected to reducer.  
 (Remove the key from straight motor shaft with key for assembly.)  
 Follow the process below from (1) through (8) for assembly.

- (1) Wipe off the antirust agent oil on the plane surfaces of the motor and reducer.
- (2) Place reducer on an appropriate worktable with output shaft on the bottom side.
- (3) Remove the plug of the setting hole ([1] in figure below) from the Adapter plate.
- (4) Turn the coupling ([3] in figure below) and align the coupling tightening bolt head to the setting hole.
- (5) a) Assemble without flange plate  
 Insert motor shaft into the center hole of the coupling, press in vertically and fit the spigot of the motor and the adapter plate.  
 b) Assemble with flange plate  
 Set the flange ([5] in figure below) between motor and adapter plate ([4] in figure below). After fitting the spigot of the flange plate and adapter plate, insert motor shaft into the center hole of the coupling, press in vertically and fit the spigot of the motor and the flange plate.
- (6) Tighten motor mounting bolts ([4] in figure below) and fix the motor and adapter plate.
- (7) Tighten the coupling tightening bolt through the setting hole using a torque wrench. Refer to Table 11 for necessary tightening torque.
- (8) Mount plug in the setting hole of the adapter plate.  
 Make sure that the selected unit can allow a maximum emergency torque in your operation cycle by using following formula.

Table 11 Bolt Tightening Torque

Coupling hole diameter mm	Tightening bolt	Tightening torque	Allowable transmission torque
		N·m	N·m
∅ 24	M8	35	212
	M10	65	212
∅ 28	M8	35	224
	M10	65	224
∅ 35	M8	35	244
	M10	65	379
	M12	102	379
∅ 42	M10	65	426
	M12	102	637
∅ 55	M12	102	782

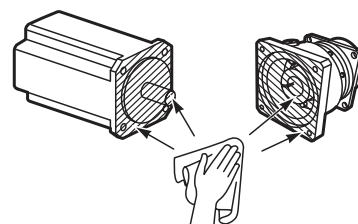

Figure 7

Make sure that the selected unit can allow maximum emergency torque in your operation cycle.

$$\frac{\text{Maximum emergency torque}}{\text{Reduction ratio}} \leq \text{Allowable transmission torque}$$

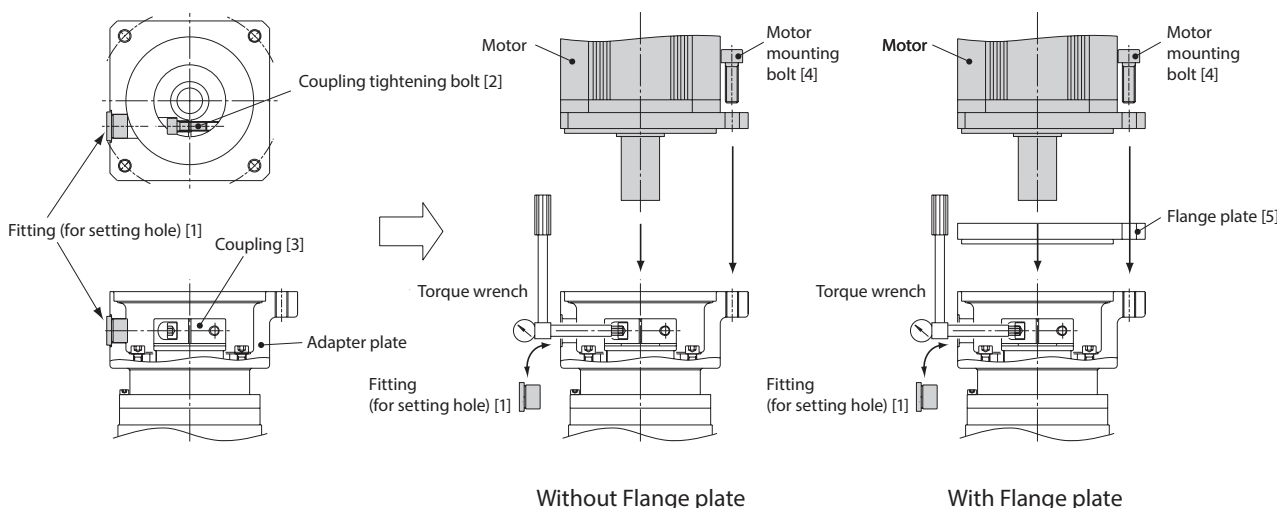

Figure 8 Assembly Diagram

# Moment of Inertia/GD<sup>2</sup> (at Motor Shaft)

## - Moment of Inertia (at Motor Shaft)

Unit: x10<sup>4</sup>kg · m<sup>2</sup>

Frame Size	Input shaft hollow [mm]	Motor flange code	Reduction ratio (single stage)							
			4		5		7		10	
			Solid shaft (Option)	Flange shaft	Solid shaft (Option)	Flange shaft	Solid shaft (Option)	Flange shaft	Solid shaft (Option)	Flange shaft
P240	∅ 24	DA	20.3	19.0	18.1	17.2	16.2	15.7	15.2	15.0
	∅ 28	1T	20.2	18.8	17.9	17.0	16.0	15.5	15.0	14.8
	∅ 35	0X,DD	19.6	18.3	17.4	16.5	15.5	15.0	14.5	14.3
	∅ 42	DE	38.3	36.9	36.0	35.1	34.1	33.6	33.1	32.9
	∅ 55h6	DJ,DK	52.8	51.4	50.5	49.6	48.6	48.2	47.6	47.4
	∅ 55m6	DL	52.8	51.4	50.5	49.6	48.6	48.2	47.6	47.4
P250	∅ 35	0X	66.5	61.3	55.1	51.7	45.7	43.9	40.8	40.0
	∅ 42	DE	65.3	60.0	53.8	50.4	44.4	42.7	39.6	38.7
	∅ 55h6	DJ,DK	77.6	72.3	66.1	62.7	56.7	54.9	51.8	51.0
	∅ 55m6	DL	77.6	72.3	66.1	62.7	56.7	54.9	51.8	51.0

Frame Size	Input shaft hollow [mm]	Motor flange code	Reduction ratio (double stage)							
			16		20		25		28	
			Solid shaft (Option)	Flange shaft	Solid shaft (Option)	Flange shaft	Solid shaft (Option)	Flange shaft	Solid shaft (Option)	Flange shaft
P240	∅ 24	1L,7Y,7Z,DA	7.13	7.04	6.60	6.54	6.50	6.47	6.60	6.57
	∅ 28	1T,DC	7.01	6.92	6.47	6.42	6.38	6.34	6.47	6.45
	∅ 35	0X,DD	6.60	6.52	6.07	6.02	5.98	5.94	6.07	6.04
	∅ 42	DE	13.3	13.2	12.8	12.7	12.7	12.6	12.8	12.7
P250	∅ 24	1L,7Y,DA	19.4	19.1	17.7	17.4	17.2	17.1	16.0	15.9
	∅ 28	1T,DC	19.3	18.9	17.5	17.3	17.0	16.9	15.8	15.7
	∅ 35	0X,DD	18.7	18.4	17.0	16.7	16.5	16.3	15.3	15.2
	∅ 42	DE	37.4	37.0	35.6	35.4	35.1	35.0	33.9	33.8
	∅ 55h6	DJ,DK	51.9	51.5	50.1	49.9	49.6	49.5	48.4	48.3
	∅ 55m6	DL	51.9	51.5	50.1	49.9	49.6	49.5	48.4	48.3

Frame Size	Input shaft hollow [mm]	Motor flange code	Reduction ratio (double stage)										
			35		40		50		70		100		
			Solid shaft (Option)	Flange shaft	Solid shaft (Option)	Flange shaft	Solid shaft (Option)	Flange shaft	Solid shaft (Option)	Flange shaft	Solid shaft (Option)	Flange shaft	
P240	∅ 24	1L,7Y,7Z,DA	6.10	6.08	5.92	5.90	5.89	5.89	5.88	5.87	5.87	5.87	5.86
	∅ 28	1T,DC	5.98	5.96	5.80	5.78	5.77	5.76	5.75	5.75	5.74	5.74	5.74
	∅ 35	0X,DD	5.58	5.56	5.39	5.38	5.37	5.36	5.35	5.35	5.34	5.34	5.34
	∅ 42	DE	12.3	12.3	12.1	12.1	12.1	12.1	12.0	12.0	12.0	12.0	12.0
P250	∅ 24	1L,7Y,DA	15.8	15.7	15.1	15.1	15.0	15.0	14.9	14.9	14.8	14.8	14.8
	∅ 28	1T,DC	15.6	15.5	14.9	14.9	14.8	14.8	14.7	14.7	14.7	14.7	14.7
	∅ 35	0X,DD	15.1	15.0	14.4	14.4	14.3	14.3	14.2	14.2	14.1	14.1	14.1
	∅ 42	DE	33.7	33.6	33.0	33.0	32.9	32.9	32.8	32.8	32.8	32.8	32.8
	∅ 55h6	DJ,DK	48.2	48.1	47.5	47.5	47.4	47.4	47.3	47.3	47.3	47.3	47.3
	∅ 55m6	DL	48.2	48.1	47.5	47.5	47.4	47.4	47.3	47.3	47.3	47.3	47.3

## - GD<sup>2</sup> (at Motor Shaft)

Unit: x10<sup>4</sup>kgf · m<sup>2</sup>

Frame Size	Input shaft hollow [mm]	Motor flange code	Reduction ratio (single stage)							
			4		5		7		10	
			Solid shaft (Option)	Flange shaft	Solid shaft (Option)	Flange shaft	Solid shaft (Option)	Flange shaft	Solid shaft (Option)	Flange shaft
P240	∅ 24	DA	81.4	75.9	72.3	68.7	64.7	62.9	60.7	59.8
	∅ 28	1T	80.7	75.2	71.6	68.1	64.0	62.2	60.0	59.1
	∅ 35	0X,DD	78.6	73.0	69.5	65.9	61.8	60.0	57.9	57.0
	∅ 42	DE	153	148	144	140	136	135	132	132
	∅ 55h6	DJ,DK	211	206	202	198	194	193	190	190
	∅ 55m6	DL	211	206	202	198	194	193	190	190
P250	∅ 35	0X	266	245	220	207	183	176	163	160
	∅ 42	DE	261	240	215	202	178	171	158	155
	∅ 55h6	DJ,DK	310	289	264	251	227	220	207	204
	∅ 55m6	DL	310	289	264	251	227	220	207	204

Frame Size	Input shaft hollow [mm]	Motor flange code	Reduction ratio (double stage)							
			16		20		25		28	
			Solid shaft (Option)	Flange shaft	Solid shaft (Option)	Flange shaft	Solid shaft (Option)	Flange shaft	Solid shaft (Option)	Flange shaft
P240	∅ 24	1L,7Y,7Z,DA	28.5	28.2	26.4	26.2	26.0	25.9	26.4	26.3
	∅ 28	1T,DC	28.0	27.7	25.9	25.7	25.5	25.4	25.9	25.8
	∅ 35	0X,DD	26.4	26.1	24.3	24.1	23.9	23.8	24.3	24.2
	∅ 42	DE	53.2	52.8	51.0	50.8	50.7	50.5	51.1	50.9
P250	∅ 24	1L,7Y,DA	77.7	76.4	70.6	69.8	68.7	68.2	64.0	63.6
	∅ 28	1T,DC	77.1	75.7	69.9	69.1	68.1	67.5	63.3	62.9
	∅ 35	0X,DD	74.9	73.6	67.8	67.0	65.9	65.4	61.2	60.8
	∅ 42	DE	149	148	142	141	140	140	136	135
	∅ 55h6	DJ,DK	207	206	200	200	198	198	194	193
	∅ 55m6	DL	207	206	200	200	198	198	194	193

Frame Size	Input shaft hollow [mm]	Motor flange code	Reduction ratio (double stage)									
			35		40		50		70		100	
			Solid shaft (Option)	Flange shaft	Solid shaft (Option)	Flange shaft	Solid shaft (Option)	Flange shaft	Solid shaft (Option)	Flange shaft	Solid shaft (Option)	Flange shaft
P240	∅ 24	1L,7Y,7Z,DA	24.4	24.3	23.7	23.6	23.6	23.5	23.5	23.5	23.5	23.5
	∅ 28	1T,DC	23.9	23.8	23.2	23.1	23.1	23.1	23.0	23.0	23.0	23.0
	∅ 35	0X,DD	22.3	22.2	21.6	21.5	21.5	21.4	21.4	21.4	21.4	21.4
	∅ 42	DE	49.1	49.0	48.3	48.3	48.2	48.2	48.2	48.1	48.1	48.1
P250	∅ 24	1L,7Y,DA	63.1	62.8	60.4	60.2	60.0	59.8	59.6	59.5	59.4	59.4
	∅ 28	1T,DC	62.4	62.1	59.8	59.5	59.3	59.2	58.9	58.8	58.7	58.7
	∅ 35	0X,DD	60.3	60.0	57.6	57.4	57.2	57.0	56.8	56.7	56.6	56.5
	∅ 42	DE	135	134	132	132	132	132	131	131	131	131
	∅ 55h6	DJ,DK	193	193	190	190	190	190	189	189	189	189
	∅ 55m6	DL	193	193	190	190	190	190	189	189	189	189

# Formula for Calculation of Moment of Inertia, Load Torque, and Acceleration Torque

## - Formula for Calculation of Moment of Inertia, Load Torque, and Acceleration Torque

Specification	Figure	Load moment of Inertia J[kgm]	Load torque of Reducer Output Shaft T[Nm]	Acceleration Torque Reducer Output Shaft T <sub>a</sub> [Nm]	Relation Ship of Output Speed and Speed N[r/min]
Object inner motion	<p>J<sub>B</sub>: Inertia of ball screw [kgm]</p>	$M\left(\frac{P}{2\pi}\right)^2 + J_B$ <p>M: Mass of Load [kg] P: Pitch of ball screw [m]</p>	$\frac{P}{2\pi} (\mu \cdot M \cdot g + F)$ <p>μ: Friction coefficient of ball screw g: Gravity acceleration [9.8m/sec<sup>2</sup>] F: External force [N]</p>	$\frac{2\pi \cdot N \cdot J_L}{60t_a}$ <p>J<sub>L</sub>: Load inertia converted to output shaft of the reducer [kgm<sup>2</sup>] N: Speed [r/min] t<sub>a</sub>: Acceleration time [sec]</p>	$\frac{V}{P}$ <p>V: Acceleration [m/min] P: Ball pitch screw [m]</p>
Hoisting object with a pulley	<p>J = J<sub>1</sub> + J<sub>2</sub> J<sub>1</sub>: Inertia of drum [kgm<sup>2</sup>] J<sub>2</sub>: Inertia of substance [kgm<sup>2</sup>]</p>	$\frac{M_1 \cdot D^2}{8} + \frac{M_2 \cdot D^2}{4}$ <p>M<sub>1</sub>: Mass of cylinder [kg] M<sub>2</sub>: Mass of suspended object [kg] D: Diameter of drum [m]</p>	$F \cdot \frac{D}{2}$ <p>F: External load [N] = M<sub>2</sub> · g g: Gravity acceleration [9.8m/sec<sup>2</sup>]</p>	$\frac{2\pi \cdot N \cdot J_L}{60t_a}$ <p>J<sub>L</sub>: Load inertia converted to output shaft of the reducer [kgm<sup>2</sup>] N: Speed [r/min] t<sub>a</sub>: Acceleration time [sec]</p>	$\frac{V}{\pi \cdot D}$ <p>V: Acceleration [m/min] D: Drum diameter [m]</p>
Transfer by rack or pinion		$\frac{M \cdot D^2}{4}$ <p>M: Mass of rack [kg] D: Pinion PCD [m]</p>	$F \cdot \frac{D}{2} + F_L$ <p>F: External force (N) g: Gravity acceleration [9.8m/sec<sup>2</sup>] F<sub>L</sub>: Contact loss [N·m]</p>	$\frac{2\pi \cdot N \cdot J_L}{60t_a}$ <p>J<sub>L</sub>: Load inertia converted to output shaft of the reducer [kgm<sup>2</sup>] N: Speed [r/min] t<sub>a</sub>: Acceleration time [sec]</p>	$\frac{V}{R}$ <p>V: Velocity [m/min] R = πdp or Zp · Lp dp: P, C, D [m] Zp: Teeth number Lp: Pitch</p>
Transfer by belt conveyor	<p>J = J<sub>1</sub> + J<sub>2</sub> + J<sub>3</sub> + J<sub>4</sub> J<sub>1</sub>: Inertia of cylinder 1 [kgm<sup>2</sup>] J<sub>2</sub>: Inertia of cylinder 2 [kgm<sup>2</sup>] J<sub>3</sub>: Inertia of substance [kgm<sup>2</sup>] J<sub>4</sub>: Inertia of belt [kgm<sup>2</sup>]</p>	$\frac{M_1 \cdot D_1^2}{8} + \frac{M_2 \cdot D_2^2}{8} + \frac{D_1^2}{D_2^2} \cdot \frac{M_3 \cdot D_1^2}{4} + \frac{M_4 \cdot D_1^2}{4}$ <p>M<sub>1</sub>: Mass of cylinder 1 [kg] M<sub>2</sub>: Mass of cylinder 2 [kg] M<sub>3</sub>: Mass of object [kg] M<sub>4</sub>: Mass of belt [kg] D<sub>1</sub>: Diameter of cylinder 1 [m] D<sub>2</sub>: Diameter of cylinder 2 [m]</p>	$\frac{1}{2} D(F + \mu \cdot M_3 \cdot g)$ <p>F: External force [N] g: Gravity acceleration [9.8m/sec<sup>2</sup>]</p>	$\frac{2\pi \cdot N \cdot J_L}{60t_a}$ <p>J<sub>L</sub>: Load inertia converted to output shaft of the reducer [kgm<sup>2</sup>] N: Speed [r/min] t<sub>a</sub>: Acceleration time [sec]</p>	$\frac{V}{D_1}$ <p>V: Velocity [m/min] D<sub>1</sub>: Diameter of cylinder 1 [m]</p>
Transfer by roll field		$J_1 + \left(\frac{D_1}{D_2}\right)^2 \cdot J_2 + \frac{M \cdot D_1^2}{4}$ <p>D<sub>1</sub>: Diameter of roll 1 [m] D<sub>2</sub>: Diameter of roll 2 [m] M: Equivalent mass of work [kg]</p>	$\frac{D(F + N \cdot \mu_1 + M \cdot g \cdot \mu_2)}{2}$ <p>F: Tension [N] g: Gravity acceleration [9.8m/sec<sup>2</sup>] N: Welding force [N]</p>	$\frac{2\pi \cdot N \cdot J_L}{60t_a}$ <p>J<sub>L</sub>: Load inertia converted to output shaft of the reducer [kgm<sup>2</sup>] N: Speed [r/min] t<sub>a</sub>: Acceleration time [sec]</p>	$\frac{N}{\pi \cdot D_1}$ <p>V: Velocity [m/min] D<sub>1</sub>: Roll diameter [m]</p>

1. Calculate inertia and make additions when using additional apparatus for each drive part.
2. Calculate each element for frictional force and convert to frictional torque at output shaft of reducer if necessary.
3. Calculate each element for external force and convert to external torque at output shaft of reducer if necessary.

# Formula for Calculation of Moment of Inertia, $GD^2$

- Formula to Calculate Moment of inertia and  $GD^2$

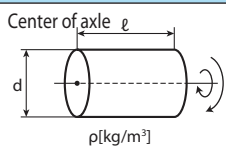
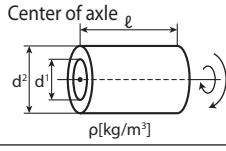
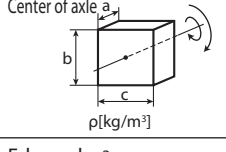
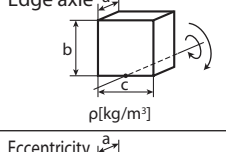
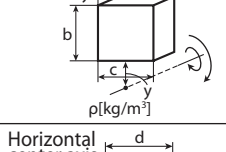
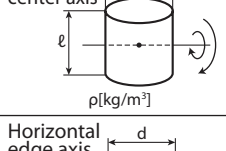
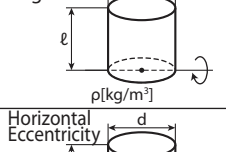
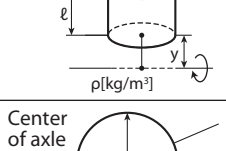
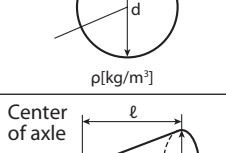
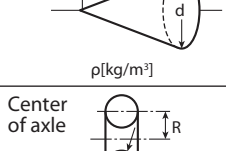
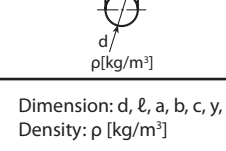
Location of the rotation	Shape	Mass M [kg]	Moment of inertia J [kgm <sup>2</sup> ]	$GD^2$ $GD^2$ [kgf·m <sup>2</sup> ]
 <p>Center of axle <math>l</math> <math>d</math> <math>\rho</math>[kg/m<sup>3</sup>]</p>	Cylinder	$\frac{1}{4} \cdot \pi \cdot d^2 \cdot l \cdot \rho$	$\frac{1}{32} \cdot \pi \cdot d^4 \cdot l \cdot \rho$	$\frac{1}{8} \cdot \pi \cdot d^4 \cdot l \cdot \rho$
 <p>Center of axle <math>l</math> <math>d_1</math> <math>d_2</math> <math>\rho</math>[kg/m<sup>3</sup>]</p>	Cylinder hollow	$\frac{1}{4} \cdot \pi \cdot (d_1^2 - d_2^2) \cdot l \cdot \rho$	$\frac{1}{32} \cdot \pi \cdot (d_1^4 - d_2^4) \cdot l \cdot \rho$	$\frac{1}{8} \cdot \pi \cdot (d_1^4 - d_2^4) \cdot l \cdot \rho$
 <p>Center of axle <math>a</math> <math>b</math> <math>c</math> <math>\rho</math>[kg/m<sup>3</sup>]</p>	Rectangular solid	$a \cdot b \cdot c \cdot \rho$	$\frac{a \cdot b \cdot c}{12} \cdot (b^2 + c^2) \cdot \rho$	$\frac{a \cdot b \cdot c}{3} \cdot (b^2 + c^2) \cdot \rho$
 <p>Edge axle <math>a</math> <math>b</math> <math>c</math> <math>\rho</math>[kg/m<sup>3</sup>]</p>	Rectangular solid	$a \cdot b \cdot c \cdot \rho$	$\frac{a \cdot b \cdot c}{12} \cdot (4b^2 + c^2) \cdot \rho$	$\frac{a \cdot b \cdot c}{3} \cdot (4b^2 + c^2) \cdot \rho$
 <p>Eccentricity <math>a</math> <math>b</math> <math>c</math> <math>y</math> <math>\rho</math>[kg/m<sup>3</sup>]</p>	Rectangular solid	$a \cdot b \cdot c \cdot \rho$	$\frac{a \cdot b \cdot c}{12} \cdot (4b^2 + c^2 + 12b \cdot y + 12y^2) \cdot \rho$	$\frac{a \cdot b \cdot c}{3} \cdot (4b^2 + c^2 + 12b \cdot y + 12y^2) \cdot \rho$
 <p>Horizontal center axis <math>d</math> <math>l</math> <math>\rho</math>[kg/m<sup>3</sup>]</p>	Cylinder	$\frac{1}{4} \cdot \pi \cdot d^2 \cdot l \cdot \rho$	$\frac{\pi \cdot d^2 \cdot l}{192} \cdot (4l^2 + 3d^2) \cdot \rho$	$\frac{\pi \cdot d^2 \cdot l}{48} \cdot (4l^2 + 3d^2) \cdot \rho$
 <p>Horizontal edge axis <math>d</math> <math>l</math> <math>\rho</math>[kg/m<sup>3</sup>]</p>	Cylinder	$\frac{1}{4} \cdot \pi \cdot d^2 \cdot l \cdot \rho$	$\frac{\pi \cdot d^2 \cdot l}{192} \cdot (16l^2 + 3d^2) \cdot \rho$	$\frac{\pi \cdot d^2 \cdot l}{48} \cdot (16l^2 + 3d^2) \cdot \rho$
 <p>Horizontal Eccentricity <math>d</math> <math>l</math> <math>y</math> <math>\rho</math>[kg/m<sup>3</sup>]</p>	Cylinder	$\frac{1}{4} \cdot \pi \cdot d^2 \cdot l \cdot \rho$	$\frac{\pi \cdot d^2 \cdot l}{192} \cdot (16l^2 + 3d^2 + 48y \cdot l + 48y^2) \cdot \rho$	$\frac{\pi \cdot d^2 \cdot l}{48} \cdot (16l^2 + 3d^2 + 48y \cdot l + 48y^2) \cdot \rho$
 <p>Center of axle <math>d</math> <math>\rho</math>[kg/m<sup>3</sup>]</p>	Sphere	$\frac{1}{6} \cdot \pi \cdot d^3 \cdot \rho$	$\frac{1}{60} \cdot \pi \cdot d^5 \cdot \rho$	$\frac{1}{15} \cdot \pi \cdot d^5 \cdot \rho$
 <p>Center of axle <math>l</math> <math>d</math> <math>\rho</math>[kg/m<sup>3</sup>]</p>	Cone	$\frac{1}{12} \cdot \pi \cdot d^2 \cdot l \cdot \rho$	$\frac{1}{160} \cdot \pi \cdot d^4 \cdot l \cdot \rho$	$\frac{1}{40} \cdot \pi \cdot d^4 \cdot l \cdot \rho$
 <p>Center of axle <math>R</math> <math>d</math> <math>\rho</math>[kg/m<sup>3</sup>]</p>	Torus	$\frac{1}{2} \cdot \pi^2 \cdot R \cdot d^2 \cdot \rho$	$\frac{\pi^2 \cdot R \cdot d^2}{8} \cdot (4R^2 + \frac{3d^2}{4}) \cdot \rho$	$\frac{\pi^2 \cdot R \cdot d^2}{2} \cdot (4R^2 + \frac{3d^2}{4}) \cdot \rho$

Dimension: d, l, a, b, c, y, R [m]  
Density:  $\rho$  [kg/m<sup>3</sup>]

# Motor Accuracy

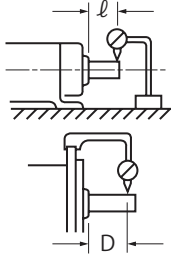
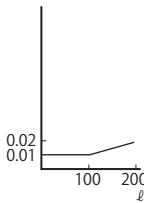
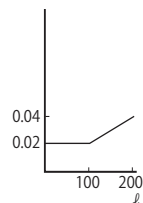
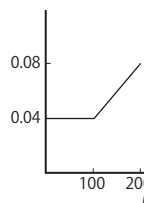
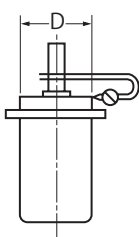
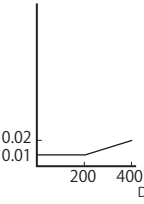
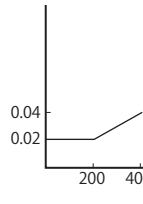
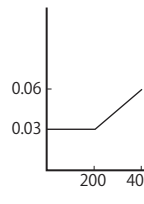
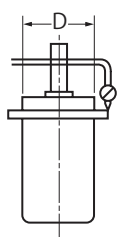
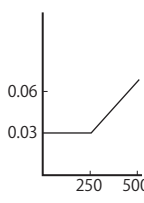
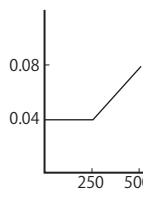
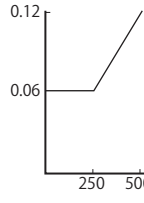
Type	Measuring item	Measuring method	Sketch of measurement	Measurement instrument	Work accuracy		
					Grade AA	Grade A	Grade B
Foot-mount type and flange type	Run-out of shaft end	Secure the dial gauge on the floor or flange surface. Place the probe of the dial gauge on the circumference close to the shaft end. Turn the shaft once. Difference between the observed maximum and minimum values is the measured value.		Dial gauge	Work accuracy = 0.01 when $\leq 100$ As below when $L > 100$	Work accuracy = 0.02 when $\leq 100$ As below when $L > 100$	Work accuracy = 0.04 when $\leq 100$ As below when $L > 100$
							
Flange type	Eccentricity of flange engagement O.D.	Secure the dial gauge on the shaft close to the flange surface. Place the probe of the dial gauge on the circumference of flange connection. Turn the shaft once. Half of the difference between the observed maximum and minimum values is the measured values.		Dial gauge	Work accuracy = 0.01 when $\leq 200$ As below when $D > 200$	Work accuracy = 0.02 when $\leq 200$ As below when $D > 200$	Work accuracy = 0.03 when $\leq 200$ As below when $D > 200$
							
Flange type	Perpendicularity with respect to flange surface	Secure the dial gauge on the shaft close to the flange surface. Place the probe of the dial gauge on the flange surface close to flange circumference. Turn the shaft once. The difference between the observed maximum and minimum values is the measured value.		Dial gauge	Work accuracy = 0.03 when $\leq 250$ As below when $D > 250$	Work accuracy = 0.04 when $\leq 250$ As below when $D > 250$	Work accuracy = 0.06 when $\leq 250$ As below when $D > 250$
							

# Warranty

Warranty Period	The warranty period for the Products shall be 18 months after the commencement of delivery or 18 months after the shipment of the Products from the seller's works or 12 months from the Products coming into operation, whichever comes first.
Warranty Condition	In the event that any problem or damage to the Product arises during the "Warranty Period" from defects in the Product whenever the Product is properly installed and combined with the Buyer's equipment or machines, maintained as specified in the maintenance manual, and properly operated under the conditions described in the catalog or as otherwise agree upon in writing between the Seller and the Buyer or its customers; the Seller will provide, at its sole discretion, appropriate repair or replacement of the Product without charge at a designated facility, except as stipulated in the "Warranty Exclusions" as described below. However, if the Product is installed or integrated into the Buyer's equipment or machines, the Seller shall not reimburse the cost of: removal or re-installation of the Product or other incidental costs related thereto, any lost opportunity, any profit loss or other incidental or consequential losses or damages incurred by the Buyer or its customers.
Warranty Exclusions	<p>Notwithstanding the above warranty, the warranty as set forth herein shall not apply to any problem or damage to the Product that is caused by:</p> <ol style="list-style-type: none"> <li>1. installation, connection, combination or integration of the Product in or to the other equipment or machine that is rendered by any person or entity other than the Seller;</li> <li>2. insufficient maintenance or improper operation by the Buyer or its customers, such that the Product is not maintained in accordance with the maintenance manual provided or designated by the Seller;</li> <li>3. improper use or operation of the Product by the Buyer or its customers that is not informed to the Seller, including, without limitation, the Buyer's or its customers, operation of the Product not in conformity with the specifications, or use of lubricating oil in the Product that is not recommended by the Seller;</li> <li>4. any problem or damage on any equipment or machine to which the Product is installed, connected or combined or on any specifications particular to the Buyer or its customers;</li> <li>5. any changes, modifications, improvements or alterations to the Product or those functions that are rendered on the Product by any person or entity other than the Seller;</li> <li>6. any parts in the Product that are supplied or designated by the Buyer or its customers;</li> <li>7. earthquake, fire, flood, sea-breeze, gas, thunder, acts of God or any other reasons beyond the control of the Seller;</li> <li>8. normal wear and tear, or deterioration of the Products, parts, such as bearings, oil-seals;</li> <li>9. any other troubles, problems or damage to the Product that are not attributable to the Seller.</li> </ol>

## SAFETY PRECAUTIONS

- Observe the safety rules for the installation site and equipments strictly (Industrial safety and health law, technical standard for electric facilities, extension rules, plant explosion guidelines, building standards law, etc).
- Read the maintenance manual carefully before use.  
Request a copy from the distributor of the Product or our Sales Department if the maintenance manual is not handy. A copy of maintenance manual should always reach the actual user of the Product.
- Select a sufficient product for the usage condition and application.
- Install protective equipment on the machine side when the machine is used for applications which may cause loss of human life or significant loss in facility, such as use for human transportation or elevators.
- Install an oil pan or other preventive devices in case of oil leakage due to failure or termination of service life when the machine is used for food processing equipment, clean room, or other applications that are sensitive to oil.



# Worldwide Locations

## U.S.A

**Sumitomo Machinery Corporation of America (SMA)**  
1453 Cornwall Blvd. Chesapeake, VA 23323, U.S.A.  
TEL (1)757-485-3355 FAX (1)757-485-7490

## Canada

**SM Cyclo of Canada, Ltd. (SMC)**  
1453 Cornwall Road, Oakville, Canada ON L6J 7T5  
TEL (1)905-469-1050 FAX (1)905-469-1055

## Mexico

**SM Cyclo de Mexico, S.A. de C.V. (SMME)**  
Av. Desarrollo 541, Col. Finsa, Guadalupe, Nuevo León, México, CP67132  
TEL (52)81-8144-5130 FAX (52)81-8144-5130

## Brazil

**Sumitomo Industrias Pesadas do Brasil Ltda. (SHIB)**  
Rodovia do Acucar (SP-075) Km 26  
Itu, Sao Paulo, Brasil  
TEL (55)11-4886-1000 FAX (55)11-4886-1000

## Chile

**SM-Cyclo de Chile Ltda. (SMCH)**  
San Pablo 3507, Quinta Normal, Santiago, Chile  
TEL (56)2-892-7000 FAX (56)2-892-7001

## Argentina

**SM-Cyclo de Argentina S.A. (SMAR)**  
Ing. Delpini, 2236 Area de Promocion el Triangulo, Partido Malvinas Argentinas Grand Bourg, Buenos Aires, Argentina B1615KGB  
TEL (54)3327-45-4095 FAX (54)3327-45-4099

## Guatemala

**SM Cyclo de Guatemala Ensambladora, Ltda. (SMGT)**  
Parque Industrial Unisur, 0 Calle B 19-50 Zona 3, Bodega D-1 Delta Bárcenas en Villa Nueva, Guatemala  
TEL (502)6648-0500 FAX (502)6631-9171

## Colombia

**SM Cyclo Colombia, S.A.S. (SMCO)**  
Carrera 11, No.93A-53, Office 203, Bogotá, Colombia  
TEL (57)1-3000673

## Germany

**Sumitomo (SHI) Cyclo Drive Germany GmbH (SCG)**  
Cyclostraße 92, 85229 Markt Indersdorf, Germany  
TEL (49)8136-66-0 FAX (49)8136-5771

## Austria

**Sumitomo (SHI) Cyclo Drive Germany GmbH (SCG)**  
SCG Branch Austria Office  
Gruentalerstraße 30A, 4020 Linz, Austria  
TEL (43)732-330958 FAX (43)732-331978

## Belgium

**Sumitomo (SHI) Cyclo Drive Germany GmbH (SCG)**  
SCG Branch Benelux Office  
Heikneuterlaan 23, 3010 Kessel-Lo, Leuven, Belgium  
TEL (32)16-60-83-11 FAX (32)16-60-16-39

## France

**SM-Cyclo France SAS (SMFR)**  
8 Avenue Christian Doppler, 77700 Serris, France  
TEL (33)164171717 FAX (33)164171718

## Italy

**SM-Cyclo Italy Srl (SMIT)**  
Via dell' Artigianato 23, 20010 Cornaredo (MI), Italy  
TEL (39)293-481101 FAX (39)293-481103

## Spain

**SM-Cyclo Iberia, S.L.U. (SMIB)**  
C/Landabari No. 3, 6<sup>o</sup> B, 48940 Leioa, Vizcaya, Spain  
TEL (34)9448-05389 FAX (34)9448-01550

## Sweden

**Sumitomo (SHI) Cyclo Drive Germany GmbH Sales Office Nordic BRO (SCG)**  
Dagsverkarvägen 14, 19736 BRO, Sweden  
TEL (46)40220031

## United Kingdom

**SM-Cyclo UK Ltd. (SMUK)**  
Unit 29, Bergen Way, Sutton Fields Industrial Estate, Kingston upon Hull, HU7 0YQ, East Yorkshire, United Kingdom  
TEL (44)1482-790340 FAX (44)1482-790321

## Turkey

**SM Cyclo Turkey Güç Aktarım Sis. Tic. Ltd. Sti. (SMTR)**  
Büyükdere Çayırbaşı Cd. Dede Yusuf Sk. No: 11, 34453 Sarıyer Istanbul, Turkey  
TEL (90)216-384-4482 FAX (90)216-384-4482

## China

**Sumitomo (SHI) Cyclo Drive China, Ltd. (SCT)**  
11F, SMEG Plaza, No. 1386 Hongqiao Road, Changning District, Shanghai, China (P.C. 200336)  
TEL (86)21-3462-7877 FAX (86)21-3462-7922

## Hong Kong

**SM-Cyclo of Hong Kong Co., Ltd. (SMHK)**  
Rm 1301, CEO Tower, 77 Wing Hong Street, Cheung Sha Wan, Kowloon, Hong Kong  
TEL (852)2460-1881 FAX (852)2460-1882

## Korea

**Sumitomo (SHI) Cyclo Drive Korea, Ltd. (SCK)**  
Royal Bldg. 9F Rm. 913, 5 Dangju-Dong, Chongno-Ku, Seoul, Korea 03173  
TEL (82)2-730-0151 FAX (82)2-730-0156

## Taiwan

**Tatung SM-Cyclo Co., Ltd. (TSC)**  
22 Chungshan N. Road 3rd., Sec. Taipei, Taiwan 104, R.O.C.  
TEL (886)2-2595-7275 FAX (886)2-2595-5594

## Singapore

**Sumitomo (SHI) Cyclo Drive Asia Pacific Pte. Ltd. (SCA)**  
15 Kwong Min Road, Singapore 628718  
TEL (65)6591-7800 FAX (65)6863-4238

## Philippines

**Sumitomo (SHI) Cyclo Drive Asia Pacific Pte. Ltd. (SCA)**  
Philippines Branch Office  
B2B Granville Industrial Complex, Carmona, Cavite 4116, Philippines  
TEL (63)2-584-4921 FAX (63)2-584-4922  
TEL (63)46-430-3591  
TEL (63)46-682-0580

## Vietnam

**SM-Cyclo (Vietnam) Co., Ltd. (SMVN)**  
Factory 2B, Lot K1-2-5, Road No. 2-3-5A, Le Minh Xuan Industrial Park, Binh Chanh Dist., HCMC, Vietnam  
TEL (84)8-3766-3709 FAX (84)8-3766-3710

## Malaysia

**SM-Cyclo (Malaysia) Sdn. Bhd. (SMMA)**  
No.7C, Jalan Anggerik Mokara 31/56, Kota Kemuning, Seksyen 31, 40460 Shah Alam, Selangor Darul Ehsan, Malaysia  
TEL (60)3-5121-0455 FAX (60)3-5121-0578

## Indonesia

**PT. SM-Cyclo Indonesia (SMID)**  
Jalan Sungkai Blok F 25 No. 09 K, Delta Silicon III, Lippo Cikarang, Bekasi 17530, Indonesia  
TEL (62)21-2961-2100 FAX (62)21-2961-2211

## Thailand

**SM-Cyclo (Thailand) Co., Ltd. (SMTH)**  
195 Empire Tower, Unit 2103-4, 21st Floor, South Sathorn Road, Yannawa, Sathorn, Bangkok 10120, Thailand  
TEL (66)2670-0998 FAX (66)2670-0999

## Australia

**Sumitomo (SHI) Hansen Australia Pty. Ltd. (SHAU)**  
181 Power St, Glendenning, NSW 2761, Australia  
TEL (61)2-9208-3000 FAX (61)2-9208-3050

## India

**Sumi-Cyclo Drive India Private Limited (SMIN)**  
Survey No. 130, Hissa No. 02, Jeevan Nagar, Off Mumbai-Bangalore Bypass, Tathawade, Pune - 411033, India  
TEL (91)20-6674-2900 FAX (91)20-6674-2901

## Japan

**Sumitomo Heavy Industries, Ltd. (SHI)**  
ThinkPark Tower, 1-1 Osaki 2-chome, Shinagawa-ku, Tokyo 141-6025, Japan  
TEL (81)3-6737-2511 FAX (81)3-6866-5160

Specifications, dimensions, and other items are subject to change without prior notice.



Power Transmission & Controls Group

Headquarter ThinkPark Tower, 1-1 Osaki 2-chome, Shinagawa-ku, Tokyo 141-6025, Japan

No.Z2008E-1.0

EA06 Printed 2017.01